

# Form C gas

---

# Index

## SECTION A GENERAL INFORMATION

<b>A1</b>	<b>Principal ship particulars</b>	<b>1</b>
<b>A2</b>	<b>Hull dimensions</b>	<b>1</b>
<b>A3</b>	<b>Ballast particulars</b>	<b>2</b>
<b>A4</b>	<b>Immersion</b>	<b>2</b>
<b>A5</b>	<b>Loaded particulars</b>	<b>2</b>
<b>A6</b>	<b>Parallel mid-body dimensions</b>	<b>3</b>
<b>A7</b>	<b>Bunker capacities</b>	<b>4</b>
<b>A8</b>	<b>Fuel consumption details</b>	<b>4</b>
<b>A9</b>	<b>Main engine particulars</b>	<b>4</b>
<b>A10</b>	<b>Auxiliary plant</b>	<b>4</b>
<b>A11</b>	<b>Power/Speed information</b>	<b>4</b>
<b>A12</b>	<b>Thrusters</b>	<b>5</b>
<b>A13</b>	<b>Fresh water</b>	<b>5</b>
<b>A14</b>	<b>Ballast capacities and pumps</b>	<b>5</b>
<b>A15</b>	<b>Mooring equipment</b>	<b>6</b>
<b>A16</b>	<b>Navigational equipment</b>	<b>7</b>
<b>A17</b>	<b>Communications equipment</b>	<b>8</b>

## SECTION B CARGO SYSTEMS

<b>B1</b>	<b>Cargo - General information</b>	<b>9</b>
<b>B2</b>	<b>Cargo tanks</b>	<b>9</b>
<b>B3</b>	<b>Cargo tank capacities</b>	<b>10</b>
<b>B4</b>	<b>Loading rates</b>	<b>10</b>
<b>B5</b>	<b>Discharging - general</b>	<b>10</b>
<b>B6</b>	<b>Discharge performances</b>	<b>11</b>
<b>B7</b>	<b>Umpumpables</b>	<b>11</b>
<b>B8</b>	<b>Vaporising umpumpables</b>	<b>11</b>
<b>B9</b>	<b>Reliquefaction plant</b>	<b>11</b>
<b>B10</b>	<b>Cooling capacity</b>	<b>12</b>
<b>B11</b>	<b>Cargo temperature lowering capability (at sea)</b>	<b>12</b>
<b>B12</b>	<b>Inert gas</b>	<b>12</b>
<b>B13</b>	<b>Cargo tank inerting/de-inerting</b>	<b>12</b>
<b>B14</b>	<b>Cargo freeing to fresh air</b>	<b>12</b>
<b>B15</b>	<b>Changing cargo grades</b>	<b>13</b>
<b>B16</b>	<b>Deck tank capacities</b>	<b>13</b>
<b>B17</b>	<b>Pre-loading cooldown</b>	<b>13</b>
<b>B18</b>	<b>Vaporiser</b>	<b>13</b>
<b>B19</b>	<b>Blower</b>	<b>13</b>
<b>B20</b>	<b>Cargo Re-Heater</b>	<b>14</b>
<b>B21</b>	<b>Hydrate control</b>	<b>14</b>
<b>B22</b>	<b>Cargo measurement</b>	<b>14</b>
<b>B23</b>	<b>Cargo sampling</b>	<b>15</b>
<b>B24</b>	<b>Cargo manifold arrangements</b>	<b>16</b>
<b>B25</b>	<b>Cargo manifold reducers</b>	<b>17</b>
<b>B26</b>	<b>Manifold Derrick/Crane</b>	<b>17</b>

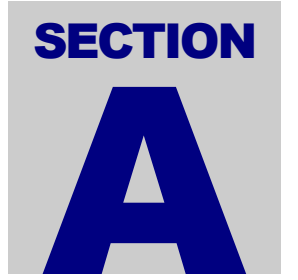

# A1 PRINCIPAL SHIP PARTICULARS

1.1	Name of Ship	<b>EXCALIBUR</b>
1.2	Previous Name(s)	<b>n/a</b>
1.3	Builder	<b>Vinashin - Bachdang</b>
1.4	Date of delivery	<b>06.04.2012</b>
1.5	Classification Society and No. RINA /	<b>R.I.Na.+ A.B.S. -- RI 85529</b>
1.6	Gross Registered Tonnage	<b>4.761</b>
1.7	Net registered Tonnage	<b>1.428</b>
1.8	Suez Tonnage Gross/Net	<b>5506,53 / 4086,11</b>
1.9	Panama tonnage Gross/Net	<b>-</b>
1.10	Registered Owner	<b>Mediterranea di Navigazione S.p.A.</b>
	Address	<b>P.zza Caduti sul Lavoro, 3 – 48122 Ravenna - Italy</b>
	Telephone	<b>+39 0544 598911</b>
	Telex/fax	<b>+39 0544 423799</b>
1.11	Manager or Operator	<b>Mediterranea di Navigazione S.p.A.</b>
	Address	<b>P.zza Caduti sul Lavoro, 3 – 48122 Ravenna - Italy</b>
	Telephone	<b>+39 0544 598911</b>
	Telex/fax	<b>+39 0544 423799</b>
1.12	Flag	<b>Italian – 2<sup>nd</sup> Register</b>
1.13	Port of registry	<b>Ravenna</b>
1.14	Official No.	<b>53</b>
1.15	Call Sign	<b>I B A P</b>
1.16	Immarsat No.	<b>Phone 00870 773140391 – fax 00870 783140269</b>
1.17	LR/IMO No.	<b>9480409</b>
1.18	Was the ship built in accordance with the following regulations	
	IMO	Yes
	USCG	Yes
	RINA	Yes
	OTHER	Yes
1.19	IMO Certification	
	Certificate of Fitness IGC	
		A328
		A329
	Letter of Compliance	
1.20	Date questionnaire compiled	<b>20.02.2015</b>

# A2 HULL DIMENSIONS

2.1	Length overall	104 m.
2.2	Length between perpendiculars	97.20 m
2.3	Extreme breadth	16.40 m.
2.4	Extreme depth	8,40 m
2.5	Summer draught	7,20 m
2.6	Corresponding deadweight	5312 tonn
2.7	Light displacement	2960 tonn
2.8	Load displacement (summer)	8355 tonn
2.9	Cargo tank cubic capacity (100%)	4655.83 cbm
2.10	Distance from keel to top antenna	33.5 m abt.
2.11	Air draught (with normal ballast)	27.5

## A3 BALLAST PARTICULARS

3.1	Permanent Ballast No	
3.2	Ballast quantity	1726 t
3.3	Bunkers, stores, etc. Fuel 428 t;	Diesel 101 t;Oils 29 t;Misc. 0 t;Fresh Water 0 t;Water 122 t
3.4	Draught	
	- Forward	4.386 m
	- Aft	5.704 m
	- Mean	5.045 m

## A4 IMMERSION

4.1	TPC at normal ballast draught	12.8 t/cm
4.2	TPC at loaded draught	14.6 t/cm

## A5 LOADED PARTICULARS

5.1	Cargo		ETHYLENE	BUTANE	PROPANE	V.C.M.
5.2	Density		0.569 t/m3	0.600 t/m3	0.583 t/m3	0.972 t/m3
5.3	Cargo	tons	2611	2748	2670 t	4364 t
5.4	Bunkers	IFO	428 t	428 t	428 t	424 t
5.5	GASOIL		101 t	101 t	101 t	101 t
5.6	Fresh water		0 t	0 t	0 t	0 t
5.7	Stores/spares		40 t	40 t	40 t	40 t
5.8	Lub oil (at 95% + bilge/sludge)		29 t	29 t	29 t	29 t
5.9	Ballast		569	506 t	504 t	359 t
5.10	Deadweight		3900 t	3975 t	3895 t	5440 t
5.11	Draught					
	- Forward		5.328 m	5.402 m	5.352 m	6.877 m
	- Aft		6.870 m	6.951 m	6.901 m	7.522 m
	- Mean		6.099 m	6.154 m	6.122 m	7.200 m

## A6 PARALLEL MID-BODY DIMENSIONS

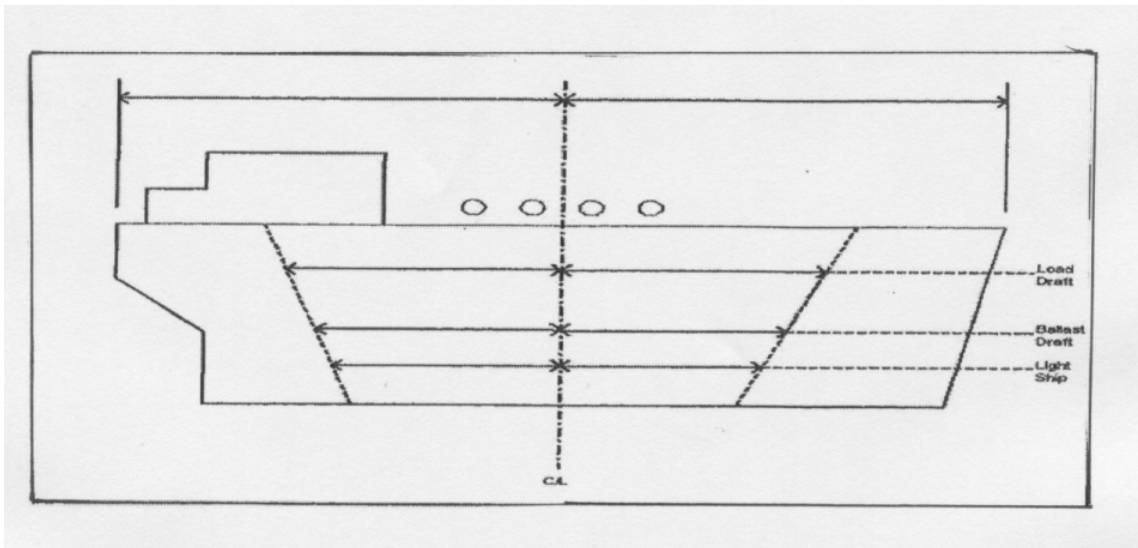

Distance bow to mid-point manifold: 58,3 m.

Distance stern to mid-point manifold: 45,6 m .

Light ship parallel body length: 47,5 m

Light ship parallel body – bow to mid-point manifold: 24,2 m

Light ship parallel body – stern to mid-point manifold: 23,3 m

Normal ballast parallel body length: 54,3 m abt.

Normal ballast parallel body length – bow to mid – point manifold: 27 m

Normal ballast parallel body length – stern to mid – point manifold: 27,3 m

Parallel body length at Summer Deadweight (SDWT): 56,3 m abt.

Parallel body length at SDWT – bow to manifold: 28 m

Parallel body length at SDWT – stern to mid – point manifold: 28,3 m

Does the ship have bulbous bow: Yes

## A7 BUNKER CAPACITIES

7.1	M.E. Fuel Oil	Grade	
		Capacity 98%	432 cbm
7.2	Diesel Oil	Grade	
		Capacity 98%	121 cbm

## A8 FUEL CONSUMPTION DETAILS

8.1	At sea (normal service speed)	<b>IFO 380 - 15,5 tonn / day</b>
8.2	At sea (normal service speed) while conditioning cargo	<b>IFO 380 – 15,5 tonn / day</b>
8.3	In port, loading	<b>3,5 tonn / day</b>
8.4	In port, discharging	<b>4,6 tonn / day</b>
8.5	In port, idle	<b>2,1 tonn / day</b>

## A9 MAIN ENGINE PARTICULARS

9.1	Main engine make and type	WARTSILA TYPE 8L32
9.2	No. of units	1
9.3	Maximum continuous rating (MCR) per engine	4000 kW – 750 RPM
9.4	Total available power	CSR
9.5	Normal service power (ECR)	CSR – 3400 kW

## A10 AUXILIARY PLANT

10.1	Make and type of auxiliary generators	VOLVO PENTA TYPE D16
10.2	No. of units	4
10.3	Maximum generator output per unit	470 kWe
10.4	Shaft generator	1600 kWe – MARELLI (WARTSILA)
10.5	Emergency generator	MAKE STX Eng. Co KOREA – 90 kW
10.6	Total available power	3480 kWe

## A11 POWER/SPEED INFORMATION

11.1	Trial data	BHP
		MCR
		Speed
		Draught
11.2	Normal service speed	BHP
		MCR
		Speed
		Draught

## A12 THRUSTERS

12.1	Make and type	THRUST MASTER&SAM ELETRONICS - 400 kW
12.2	No. Installed	1
12.3	Location and rated bollard pull	Abt fr. 131

## A13 FRESH WATER

13.1	Capacity of distilled tanks	9.10 cbm
13.2	Capacity of domestic tanks	115.11 cbm
13.3	Daily consumption distilled domestic	8.05 cbm
13.4	Daily evaporator production	10 t/day

## A14 BALLAST CAPACITIES AND PUMPS

Fill the following table

	Tank	Capacity CBM	CBM
14.1	Fore peak	136	
14.2	Wing or side tanks	1899	
14.3	Double bottoms	n/a	
14.4	Aft peak	18	
14.5	Other (.....)	n/a	
14.6		Total	2054
14.7	Ballast pump make and type	GARBARINO – TYPE MU150-315LE	
14.8	No. of Pumps	2 (N° 1 Service; N° Spare)	
14.9	Total capacity	2 x 460 cbm/H x 30 m.w.l	
14.10	Location	Engine Room	
14.11	Control Location	C.C.R./Locally	



# A15 MOORING EQUIPMENT

## 15.1 Ropes and Wires.

On the diagram below indicate the position of winch mounted ropes (R) together with open (O) and (Panama) closed (C) fairleads.

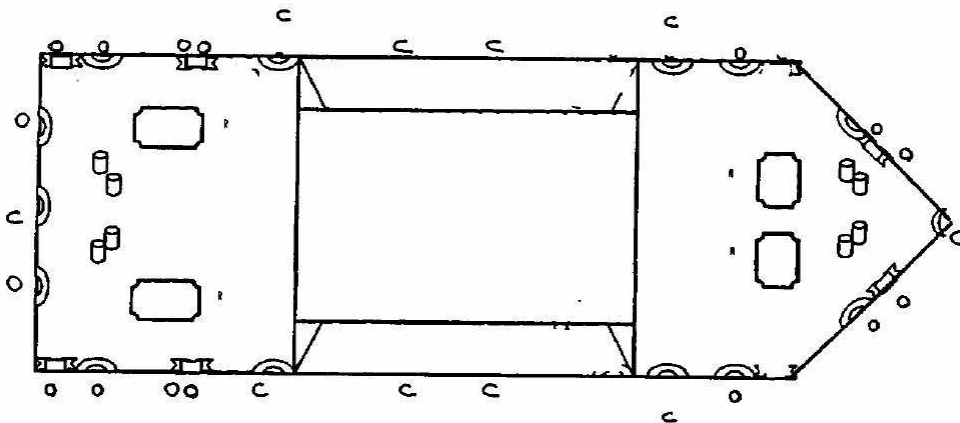

## 15.2 Mooring Winches

	No	Motive power (steam,hydraulic)	Heaving power	Brake Capacity	Hauling speed
Forecastle	2	hydraulic	tbd	27 t	12 m/min
Poop	2	hydraulic	tbd	27 t	12 m/min

## 15.3 Anchors and Windlasses

Windlass motive Power (steam, hydraulic)	hydraulic
Hauling power	tbd
Brake holding capacity	70 t
Date of last test	

Anchor type	HHP ANCHOR BALANCED
Weight	2295 kg
Is spare carried	No
Cable diameter	44 mm

No of shackles port	
No of shackles starboard	

## 15.4

Windage	
Windage on ballast draught	

Windage full loaded

# A16 NAVIGATIONAL EQUIPMENT

Is the following equipment fitted :

16.1	Magnetic compass	YES
16.2	Gyro compass and repeaters	YES
16.3	Radars	YES
16.4	Radar plotting equipment	YES
16.5	Arpa	YES
16.6	Echo sounder	YES
16.7	Speed/Distance indicator	YES
16.8	Doppler log	YES
16.9	Rudder angle, RPM, controllable pitch and Thrusters indicators	YES
16.10	Rate of turn indicator	tbd YES
16.13	Satellite navigator	YES
16.14	Decca navigator	NO
16.15	Loran C	NO
16.16	Sextants	YES
16.17	Signal lamp (aldis)	YES
16.18	Course recorder	YES
16.19	Engine order printer	YES
16.20	What chart outfit coverage is provided if limited, indicate areas covered	
16.21	Formal chart correction system in use	

# A17 COMMUNICATION EQUIPMENT

Is the following equipment fitted :

17.1	Is ship with GMDSS	YES	YES
17.2	Radio telegraph main transmitter including facility to transmit on radio telephone distress frequency	YES	YES
17.3	Radio telegraph main receiver including facility to receive on radio telephone distress frequency	YES	YES
17.4	Radio telephone distress frequency watch receiver	YES	YES
17.5	Main radio antenna	YES	YES
17.6	Radio telegraph reserve transmitter	n/a	
17.7	Radio telegraph reserve receiver	n/a	
17.8	Reserve radio antenna	YES	YES
17.9	Are the main and reserve installation electrically separate and electrically independent of each other	YES	YES
17.10	Radio telegraph auto alarm	NO	
17.11	2182 KHZ bridge watch receiver	NO	
17.12	Alarm signal generating device	YES	
17.13	VHF radio	YES	
17.14	Inmarsat satellite communications system	YES	
	if yes, state identification number		<b>00870 765040711/12/13</b>
17.15	Telex	YES	
	if yes, state identification number		<b>0580 424729315/20</b>
17.16	Telefax	YES	
	if yes, state identification number		<b>00870 765040714</b>
17.17	Weatherfax	YES	
17.18	Epirbs	YES	
17.19	At least three survival craft two-way radio telephone apparatus	YES	
17.20	Emergency lifeboat transmitter	YES	
17.21	Full set of publications	YES	
17.22	Satellite Epirb	YES	
17.23	VHF Epirb	NO	
17.24	Radio transponder for survival craft	YES	

**SECTION**  
**B**

# B1 CARGO - GENERAL INFORMATION

1.1 List products which the ship is certified to carry

Acetaldehyde  
 Anhydrous Ammonia  
 Butadiene  
 Butanes (iso and normal)  
 Butylenes  
 Butane / Propane Mixtures  
 Propane  
 Commercial Propane (max. Ethane in liquid phase 2.5 mol. %)  
 Propylene  
 Vinyl Chloride Monomer  
 Isoprene  
 Ethane  
 Butadiene and C4 Hydrocarbon Mixtures  
 Ethylene

1.2 Minimum allowable tank temp.

**-104 °C**

1.3 Maximum permissible tank pressure

**8.0 Barg**

1.4 List grades which can be transported simultaneously

Acetaldehyde  
 Anhydrous Ammonia  
 Butadiene  
 Butanes (iso and normal)  
 Butylenes  
 Butane / Propane Mixtures  
 Propane  
 Commercial Propane (max. Ethane in liquid phase 2.5 mol. %)  
 Propylene  
 Vinyl Chloride Monomer  
 Isoprene  
 Ethane  
 Butadiene and C4 Hydrocarbon Mixtures  
 Ethylene

1.5 List grades which can be loaded or discharged simultaneously

Acetaldehyde  
 Anhydrous Ammonia  
 Butadiene  
 Butanes (iso and normal)  
 Butylenes  
 Butane / Propane Mixtures  
 Propane  
 Commercial Propane (max. Ethane in liquid phase 2.5 mol. %)  
 Propylene  
 Vinyl Chloride Monomer  
 Isoprene  
 Ethane  
 Butadiene and C4 Hydrocarbon Mixtures  
 Ethylene

1.6 State natural tank segregation. (N.B. separation obtained by the removal of spools or by insertion of blind flange)

**Yes (by spool pieces removal)**

## CARGO SYSTEMS

- 1.7 Number of products, (gas) that can be conditioned by reliquefaction **2 (two)** simultaneously.

## B2 CARGO TANKS

- 2.1 No. and type of cargo tanks **2 (two independent Type C)**
- 2.2 Maximum allowable relief valve setting **8.0 Barg**
- 2.3 Safety valve set pressure - if give range for pilot valve variable **8.0 Barg (IMO Setting)**  
**6.0 Barg (USCG Setting)**
- 2.4 Maximum vacuum **0.75 Bar abs**
- 2.5 Maximum cargo density **966 kg/m<sup>3</sup>**
- 2.6 Maximum rate of cool-down
- 2.7 State any limitations regarding partially filled tanks
- 2.8 State allowable combinations of filled and empty tanks

## B3 CARGO TANK CAPACITIES

Complete the following table

TANK	Capacity CBM		PROPANE	AMMONIA	BUTANE	VCM
	100%	98%	Tonnes -42.8°C	Tonnes -33°C	Tonnes -0,5°C	Tonnes -13,4°C
1	2157	2114	1231	1441	1273	2043
2	2374	2326	1355	1586	1401	2249
3						
4						
5						
6						
<b>TOTALS</b>						

## B4 LOADING RATES

	PRODUCT	RATE (Tonnes/hr)	
		With vapour return	Without return
4.1	From refrigerated storage		
4.2	BUTANE	480	320
4.3	PROPANE	465	210
4.4	AMMONIA	545	250
4.5	ETHYLENE	454	165
4.6			
4.7			
	PRODUCT	RATE (Tonnes/hr)	
		With vapour return	Without return
4.8	From pressure storage		
4.9	BUTANE 0-30°C	480	60
4.10	PROPANE 0°C	465	22
4.11	10° C	465	12
4.12	20° C	465	
4.13	30° C	465	

## B5 DISCHARGING - GENERAL

Cargo pumps

5.1	Type of pumps	<b>Centrifugal Deepwell Pump</b>
5.2	Number per tank	<b>1 (one)</b>
5.3	Rate (per pump)	<b>400 m<sup>3</sup>/hr</b>
5.4	Delivery head	<b>120 m.l.c.</b>
5.5	Maximum density	<b>0.972 kg/l</b>
	Booster pumps	
5.6	Type of pump	<b>Centrifugal Pump (Horizontal)</b>
5.7	Number	<b>1 (one)</b>
5.8	Rate (per pump)	<b>400 m<sup>3</sup>/hr</b>
5.9	Delivery head	<b>120 m.l.c.</b>
5.10	Maximum density	<b>0.69 kg/l</b>

# B6 DISCHARGE PERFORMANCES

Full cargo discharge times (using all main pumps)

		MANIFOLD BACK PRESSURE		Hours	
				With vapour return	Without return
6.1	From refrigerated				
6.2		4		4	6
6.3		7		5.5	5.6
6.4		14		11	11
<hr/>					
		MANIFOLD BACK PRESSURE		Hours	
				With vapour return	Without return
6.5	Pressurized				
6.6		4		3.7	3.7
6.7		7		4	6
6.8		14		11	11

# B7 UNPUMPABLES

	TANK NO.	1	2	3	4	5	6	TOTAL TONNES
7.1	Vapour							
7.2	Liquid							
7.3								Total quantity

# B8 VAPORISING UNPUMPABLES

8.1	Process used	<b>WARMING</b>
	Time to vaporise liquid unpumpables remaining after full cargo discharge :	
8.2	- Propane	<b>2 Hrs</b>
8.3	- Butane	<b>8 Hrs</b>
8.4	- Ammonia	<b>6 Hrs</b>
8.5	- Propylene	<b>2 Hrs</b>
8.6	-	<b>- hrs</b>
8.7	-	<b>- hrs</b>

# B9 RELIQUEFACTION PLANT

9.1 Plant design conditions

9.2	Plant type :		
9.2	Single stage/direct	<input type="checkbox"/>	X <input type="checkbox"/>
9.3	Two stage/direct	X <input type="checkbox"/>	<input type="checkbox"/>
9.4	Simple cascade	X <input type="checkbox"/>	<input type="checkbox"/>
9.5	Coolant type	<b>Sea Water / Refrigerant (Propylene)</b>	
	Compressors		
9.6	Type	<b>BCA - 2K 140-2H</b>	
9.7	Number	<b>2 (two)</b>	
9.8	Capacity (per unit)	<b>40 - 520 kWR</b>	
9.9	Are they oil-free	<b>YES</b>	



## B10 COOLING CAPACITY

State cooling capacity (in Kcal/hr) for :

10.1	Propane	@ -42°C	<b>90283 Kcal/hr</b>
10.2		@ -20°C	<b>171970 Kcal/hr</b>
10.3		@ - 5°C	<b>266550 Kcal/hr</b>
10.4	Butane	@ - 5°C	<b>171970 Kcal/hr</b>
10.5		@ 0°C	<b>180570 Kcal/hr</b>
10.6		@ 0°C	<b>180570 Kcal/hr</b>

## B11 CARGO TEMPERATURE LOWERING CAPABILITY (AT SEA)

Time taken to lower the temperature of:

11.1	Propane from	+10°C to -42°C	<b>148 Hours</b>
11.2		-5°C to -42°C	<b>131 Hours</b>
11.3		-38°C to -42°C	<b>28 Hours</b>
11.4		+20°C to -0.5°C	<b>21 Hours</b>
11.5		+10°C to -0.5°C	<b>12 Hours</b>
11.6	Butane from	+20°C to -0.5°C	<b>45 Hours</b>
11.7		+ 10°C to -0.5°C	<b>26 Hours</b>
11.8		+10°C to -5°C	<b>43 Hours</b>
11.9	Ethylene from	-95°C to -103°C	<b>54 Hours</b>
11.10	Ethylene from	-98°C to -103°C	<b>37 Hours</b>

## B12 INERT GAS

Main inert gas and nitrogen plant

12.1	Type of system	<b>Membrane</b>
12.2	Capacity	<b>450 Nm<sup>3</sup>/hr</b>
12.3	Composition of inert gas	<b>N<sub>2</sub> &gt; 99.0%</b> <b>O<sub>2</sub> &lt; 1.0 % Vol.</b> <b>CO<sub>2</sub> &lt; 1.0 ppm</b> <b>-55 °C atmospheric</b>
12.4	Dewpoint	
12.5	Used for	<b>Piping flushing and blanketing</b> <b>Cargo Tanks inertization</b>
	Nitrogen	
12.6	No of bottles	
12.7	Capacity (each one)	
12.8	Used for	

## B13 CARGO TANK INERTING/DE-INERTING

13.1	Time taken from fresh air to under 5% O <sub>2</sub> at -25°C dewpoint	<b>11 hours</b>
	Time taken from cargo vapour to fully inert at -25°C dewpoint	<b>35 hours</b>
13.2	When : Inert gas density less than product	<b>35 hours</b>
	Inert gas density greater than product	<b>35 hours</b>

## B14 GAS FREEING TO FRESH AIR

14.1	Plant used	<b>Cargo compressors</b>
14.2	Time taken from fully inerted condition to fully breathable fresh air	<b>11 hours</b>

## B15 CHANGING CARGO GRADES

In this table write down time to change products (in hrs). Write also consumption of nitrogen.

From To	PROPANE TIME/CONS.	BUTANE TIME/CONS.	PROPYLENE TIME/CONS.	AMMONIA TIME/CONS.	VCM TIME/CONS.
PROPANE		21 / 12	21 / 12	40 / 23	40 / 23
BUTANE				40 / 23	40 / 23
PROPYLENE	21 / 12	40 / 23		85 / 36	40 / 23
AMMONIA					
VCM	40 / 23	60 / 27	40 / 23	85 / 36	

## B16 DECK TANK CAPACITY

16.1	Propane capacity	20 Cbm
16.2	Butane capacity	20 Cbm
16.3	Ammonia capacity	20 Cbm
16.4	Nitrogen capacity	N.A. Ncm

## B17 PRE-LOADING COOLDOWN

In the table below, show time and quantity of coolant required to cooldown cargo tanks from ambient temperature and fully gassed up state sufficient to allow loading to commence.

	PRODUCT	QUANTITY REQUIRED	TIME	
			With return line	Without return
17.1	ETHYLENE	90	12	16
17.2	PROPANE	44	6	8
17.3	BUTANE	15	2	3
17.4	AMMONIA	11	5	6
17.5	VINYL	27	4	5

## B18 VAPORISER

18.1	Type of vaporiser	Shell and Tube Heat Exchanger
18.2	Number fitted	1 (one)
18.3	Capacity (per unit)	250000 kcal/hr
18.4	Liquid supply rate	2000 kg/hr
18.5	Delivery temperature	

## B19 BLOWER

19.1	Type of blower	n.a.
19.2	Rated capacity	
19.3	Delivery pressure	

## B20 CARGO RE-HEATER

20.1	Type of re-heater	Shell and tube heat exchanger
20.2	Number fitted	1
20.3	Heating medium	Seawater
	Discharge rates with sea water at 15°C to raise product temperature:	
20.4	for propane from -42°C to -5°C	232 tonnes / hr
20.5	for ammonia from -33°C to 0°C	210 tonnes / hr

## B21 HYDRATE CONTROL

- 21.1 Freezing point temperature of Depressant
- 21.2 Quantity of Depressant carried
- 21.3 Means of injection

## B22 CARGO MEASUREMENT

- LEVEL GAUGES
  - 21.1 Are level gauges local or remote
  - 21.2 Manufacturer
  - 21.3 Type
  - 21.4 Rated accuracy
  - 21.5 Certifying authority
- TEMPERATURE GAUGES
  - 22.6 Manufacturer
  - 22.7 Type
  - 22.8 Rated accuracy
  - 22.9 Certifying authority
- PRESSURE GAUGES
  - 22.10 Manufacturer
  - 22.11 Type
  - 22.12 Rated accuracy
  - 22.13 Certifying authority
- OXYGEN ANALYSER
  - 22.14 Manufacturer
  - 22.15 Type
- FIXED GAS DETECTOR
  - 22.16 Manufacturer
  - 22.17 Type
  - 22.18 No of points detected
- PORTABLE GAS DETECTOR
  - 22.19 Number
  - 22.20 Manufacturer
  - 22.21 Type
- TOXIC GAS INDICATOR
  - 22.22 Number
  - 22.23 Type
- TOXIC GAS INDICATOR TUBES
  - 22.24 Number
  - 22.25 Products
- 22.26 Exp.dates
- TANKSCOPE
  - 22.27 Type

# B23 CARGO SAMPLING

23.1 Fill the following table

CARGO TANKS	SAMPLE			POINTS BOTTOM
	TOP	MIDDLE		
1	<b>Yes</b>	<b>Yes</b>		<b>Yes</b>
2	<b>Yes</b>	<b>Ye</b>		<b>Yes</b>
3				
4				
5				
6				

23.2 Can sample be drawn from:

- Tank vapour outlet
- Manifold liquid line **Yes**
- Manifold vapour line **Yes**
- Pump discharge line **Yes**

23.3 State connection type and size

# B24 CARGO MANIFOLD ARRANGEMENTS

AFT

FORE

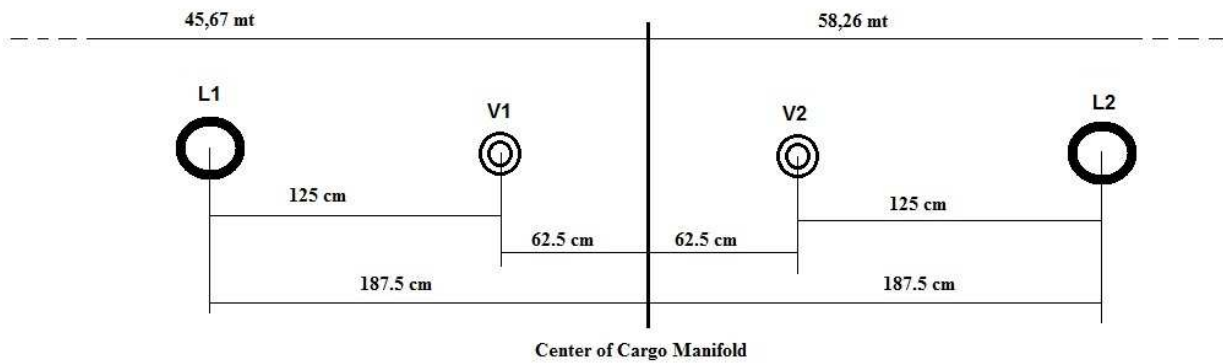

PIPE FLANGE	DUTY	RATING	SIZE	RAISED ® or Flat (F) face
L1	LIQUID SYSTEM I	ANSI 300	8"	R
V1	VAPOUR SYSTEM I	ANSI 150	4"	R
V2	VAPOUR SYSTEM II	ANSI 150	4"	R
L2	LIQUID SYSTEM II	ANSI 300	8"	R

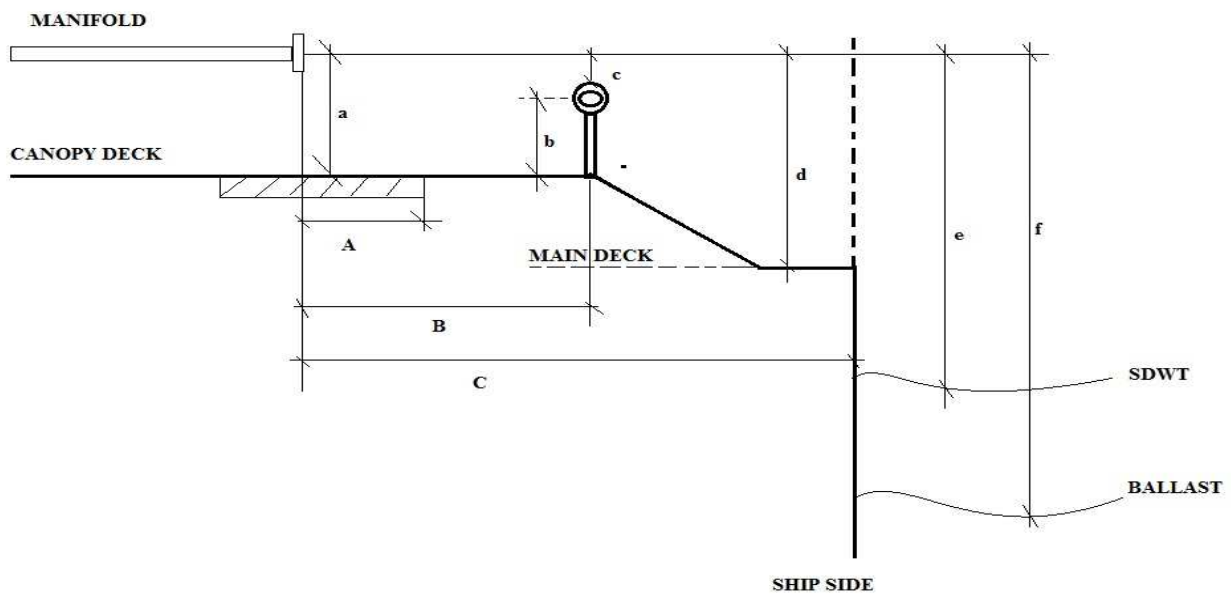

- a) Spill tank grating to center manifold 1480 mm
- b) Continuous deck to Ship's rail 900 mm
- c) Ship's rail to center manifold (height) 580 mm
- d) Main deck to center manifold 5280 mm
- e) Height of manifold above water line at SDWT 7,68 mt
- f) Height of manifold above water line at normal ballast condition 8,50 mt
  
- A) Distance from manifold to spill tank end 1,50 mt
- B) Distance from manifold to ship's rail (canopy deck) 2,55 mt
- C) Distance from manifold to ship's side 3,70 mt

**B 24bls CARGO MANIFOLD only port side Main Deck**

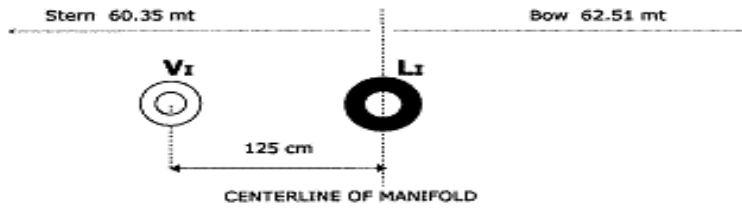

Pipe Flange	Duty	Rating	Size	Raised (R) or Flat (F) face
L1	Liquid system I	Ansi 300	8"	R
V1	Vapour " I	Ansi 150	6"	R

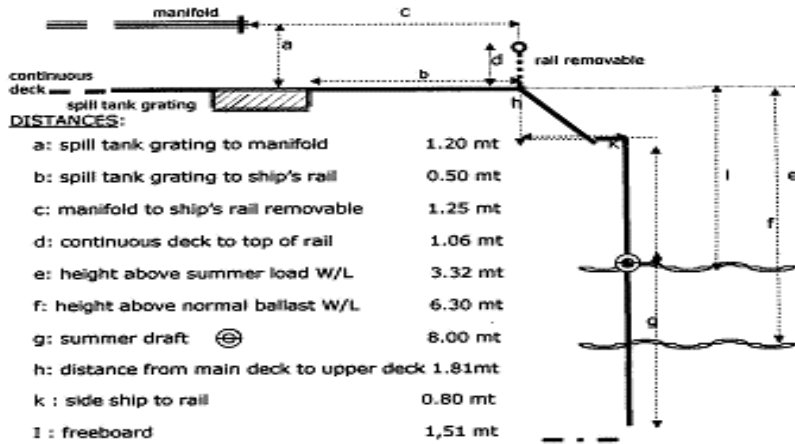

## B25 CARGO MANIFOLD REDUCERS

State number of reducers carried on board and their flange rating and size

- 25.1
- 25.2
- 25.3
- 25.4
- 25.5
- 25.6
- 25.7
- 25.8

## B26 MANIFOLD DERRICK/CRANE

- |      |  |                 |
|------|--|-----------------|
| 26.1 | Is Manifold Derrick provided                 | NO              |
| 26.2 | Is Manifold Crane provided                   | SI              |
| 26.3 | Is lifting equipment same port and starboard | NO<br>1 MIDSHIP |
|      | If not give details                          |                 |
| 26.4 | State SWL at maximum outreach                | 5 tons          |