

FORM C GAS

LAST UPDATE:

SYN ACRAB



MODEL

Form C gas

Index

SECTION A GENERAL INFORMATION

A1	Principal ship particulars	1
A2	Hull dimensions	1
A3	Ballast particulars	2
A4	Immersion	2
A5	Loaded particulars	2
A6	Parallel mid-body dimensions	3
A7	Bunker capacities	4
A8	Fuel consumption details	4
A9	Main engine particulars	4
A10	Auxiliary plant	4
A11	Power/Speed information	4
A12	Thrusters	5
A13	Fresh water	5
A14	Ballast capacities and pumps	5
A15	Mooring equipment	6
A16	Navigational equipment	7
A17	Communications equipment	8

SECTION B CARGO SYSTEMS

B1	Cargo - General information	9
B2	Cargo tanks	9
B3	Cargo tank capacities	10
B4	Loading rates	10
B5	Discharging - general	10
B6	Discharge performances	11
B7	Umpumpables	11
B8	Vaporising umpumpables	11
B9	Reliquefaction plant	11
B10	Cooling capacity	12
B11	Cargo temperature lowering capability (at sea)	12
B12	Inert gas	12
B13	Cargo tank inerting/de-inerting	12
B14	Cargo freeing to fresh air	12
B15	Changing cargo grades	13
B16	Deck tank capacities	13
B17	Pre-loading cooldown	13
B18	Vaporiser	13
B19	Blower	13
B20	Cargo Re-Heater	14
B21	Hydrate control	14
B22	Cargo measurement	14
B23	Cargo sampling	15
B24	Cargo manifold arrangements	16
B25	Cargo manifold reducers	17
B26	Manifold Derrick/Crane	17

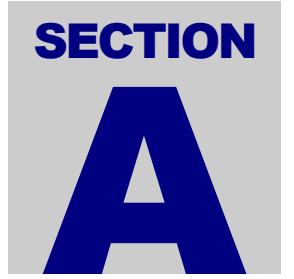

A1 PRINCIPAL SHIP PARTICULARS

1.1	Name of Ship	SYN ACRAB
1.2	Previous Name(s)	VAL DERICE
1.3	Builder	Cantiere Navale Pesaro
1.4	Date of delivery	30Oct2003
1.5	Classification Society and No.	RINA No.79065 – Bureau Veritas No 04815L
1.6	Gross Registered Tonnage	7.605
1.7	Net registered Tonnage	2.527
1.8	Suez Tonnage Gross/Net	8.822,17/7.488,42
1.9	Panama tonn. Total Volume m3/Net	26.370/ 6568
1.10	Registered Owner	SYNERGAS Srl
	Address	Via Riviera di Chiaia 82 - Napoli - Italy
	Telephone	0039 0819637170
	Telex/fax	0039 0813313110
1.11	Manager or Operator	SYNRGAS Srl
	Address	Via Riviera di Chiaia 82 - Napoli - Italy
	Telephone	0039 0819637170
	Telex/fax	0039 0813313110
1.12	Flag	Italian
1.13	Port of registry	Napoli
1.14	Official No.	317 R.I.
1.15	Call Sign	IBGK
1.16	Immarsat No.	247095300
1.17	LR/IMO No.	9251781
1.18	Was the ship built in accordance with the following regulations	
	IMO	YES
	USCG	YES
	RINA	YES
	OTHER	BUREAU VERITAS
1.19	IMO Certification	
	Certificate of Fitness IGC	YES
	A328	
	A329	
	Letter of Compliance	NO
1.20	Date questionnaire compiled	

A2 HULL DIMENSIONS

2.1	Length overall	122,84 mt
2.2	Length between perpendiculars	115,50 mt
2.3	Extreme breadth	19,02 mt
2.4	Extreme depth	9,51 mt
2.5	Summer draught	8,00 mt
2.6	Corresponding deadweight	9352,1 Tonnes
2.7	Load displacement	3869,2 Tonnes
2.8	Load displacement (summer)	13221,3 Tonnes
2.9	Cargo tank cubic capacity (100%)	9033,23 cbm
2.10	Distance from keel to top antenna	34,50
2.11	Air draught (with normal ballast)	28,50 m

A3 BALLAST PARTICULARS

3.1	Permanent Ballast		Tonnes
3.2	Ballast quantity		3568,93 Tonnes
3.3	Bunkers, stores, etc.		950,00 Tonnes
3.4	Draught	- Forward	4,60 mt
		- Aft	6,00 mt
		- Mean	5,30 mt

A4 IMMERSION

4.1	TPC at normal draught	18,05 Tonnes	at 5,30 mt mean draught
4.2	TPC at loaded draught	19,85 Tonnes	at 7,00 mt mean draught

A5 LOADED PARTICULARS

		Ethylene	VCM	Ammoniaca	Propano
5.1	Cargo				
5.2	Density	0,569	0,8262	0,682	0,583
5.3	Cargo	5,025	7,445	6,022	5,148
5.4	Bunkers	525	525	525	559
5.5	GASOIL	157	157	157	158
5.6	Fresh water	192	192	192	192
5.7	Stores/spares	15	15	15	165
5.8	Lub oil	40	40	40	40
5.9	Ballast	730	434	444	1,359
5.10	Deadweight	6,684 m	8,808	7,395	7,436
5.11	Draught				
	- Forward	6,374 m	7,687 m	6,632 m	6,553 m
	- Aft	7,030 m	7,850 m	7,474 m	7,585 m
	- Mean	6,702 m	7,768 m	7,053	7,069

A6 PARALLEL MID-BODY DIMENSIONS

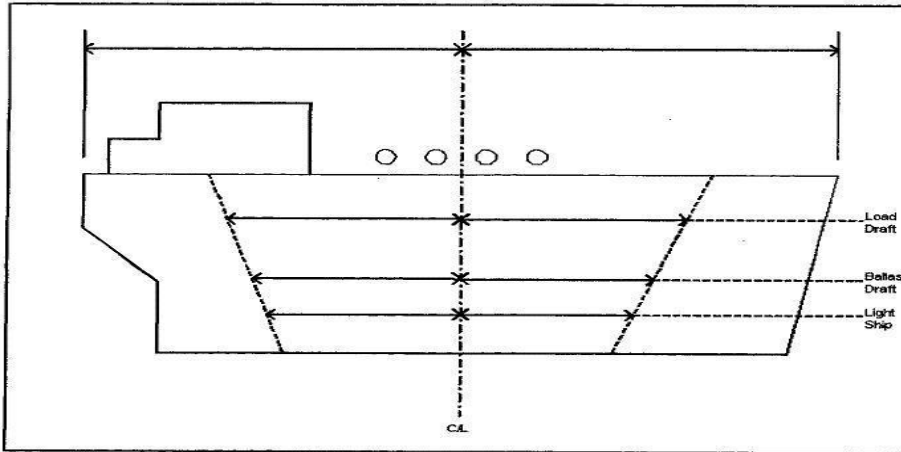

PARALLEL MID-BODY DIAGRAM

Distance bow to mid-point manifold	64,39 mt
Distance stern to mid-point manifold	58,47 mt
Light ship parallel body length	45,00 mt
Light ship parallel body – bow to mid-point manifold	22,00 mt
Light ship parallel body – stern to mid-point manifold	23,00 mt
Normal ballast parallel body length	54,00 mt
Normal ballast parallel body length – bow to mid-point manifold	26,00 mt
Normal ballast parallel body length – stern to mid-point manifold	28,00 mt
Parallel body length at Summer Deadweight (SDWT)	71,00 mt
Parallel body length at SDWT – bow to manifold	35,00 mt
Parallel body length at SDWT – stern to mid-point manifold	36,00 mt
Does the ship have bulbous bow	YES

A7 BUNKER CAPACITIES

7.1	M.E. Fuel Oil	Grade	IFO 380	(δ : 0,980)
		Capacity 98%	560 Tonnes	
7.2	Diesel Oil	Grade	(δ : 0,840)	
		Capacity 98%	140 Tonnes	

A8 FUEL CONSUMPTION DETAILS

8.1	At sea (normal service speed)	FO	ton/day	17 mt
		GO -	ton/day	0
8.2	At sea (normal service speed) while conditioning cargo	FO	ton/day	17,5 mt
		GO	ton/day	0 (with shaft generator)
8.3	In port, loading	FO	ton/day	0
		GO	ton/day	7,5 (with 3 ddgg & 2 plants running)
8.4	In port, discharging	FO	ton/day	0
		GO	ton/day	4,5 (with 2 ddgg & 4 deepwell pumps)
8.5	In port, idle	FO	ton/day	0
		GO	ton/day	2

A9 MAIN ENGINE PARTICULARS

9.1	Main engine make and type	MAK 9 M 32 C	four strokes, single acting, non reversible, 9 cylinders
9.2	No. of units	1	
9.3	Maximum continuous rating (MCR) per engine	600 rpm	
9.4	Total available power	4,320 KW	
9.5	Normal service power (ECR)	85%= 3,672 KW / 5083 HP	

A10 AUXILIARY PLANT

10.1	Make and type of auxiliary generators	CATERPILLAR	Tipe CAT 3508 BTDA
10.2	No. of units	3	
10.3	Maximum generator output per unit	Kilowatts	900
10.4	Shaft generator	Kilowatts	1100
10.5	Emergency generator	Kilowatts	130
10.6	Total available power	Kilowatts	3,800

A11 POWER/SPEED INFORMATION

11.1	Trial data	BHP	5837 HP – 3758 kw (rpm 129)
		MCR	SHP 100%
		Speed	Knots 16,9
		Draught	mt 5,30 (mean draught)

GENERAL INFORMATION

11.2	Normal service speed	BHP	5083 HP – 3332 kw (rpm 129)
		MCR	SHP 85% (with shaft generator)
		Speed	Knots 15,0
		Draught	mt 7,00 (mean draught)

A12 THRUSTERS

12.1	Make and type	Rolls Royce IT 1100 CPKI Type SCANA VOLDA
12.2	No. Installed	1
12.3	Location and rated bollard pull	Bow 540 HP – 400KW

A13 FRESH WATER

13.1	Capacity of distilled tanks	Cbm 1
13.2	Capacity of domestic tanks	Cbm 195,3
13.3	Daily consumption distilled domestic	tons 0,5 Tons 5/6
13.4	Daily evaporator production	Tons 6/7

A14 BALLAST CAPACITIES AND PUMPS

Fill the following table

	Tank	Capacity CBM	CBM
14.1	Fore peak	226	
14.2	Wing or side tanks	589	
14.3	Double bottoms	92	
14.4	Aft peak	228	
14.5	Other (3- 4- 5- 6- 7 port & stb)	2440	
14.6		Total	3,575
14.7	Ballast pump make and type	GARBARINO – MU 150/315 LE	
14.8	No. of Pumps	1 on service - two on reserve)	
14.9	Total capacity	400 cbm/hr	
14.10	Location	ENGINE ROOM	
14.11	Control Location	CCR & LOCAL	

A15 MOORING EQUIPMENT

15.1 Ropes and Wires.

On the diagram below indicate the position of winch mounted wires(W) and ropes (R) together with open (O) and closed (C) fairleads.

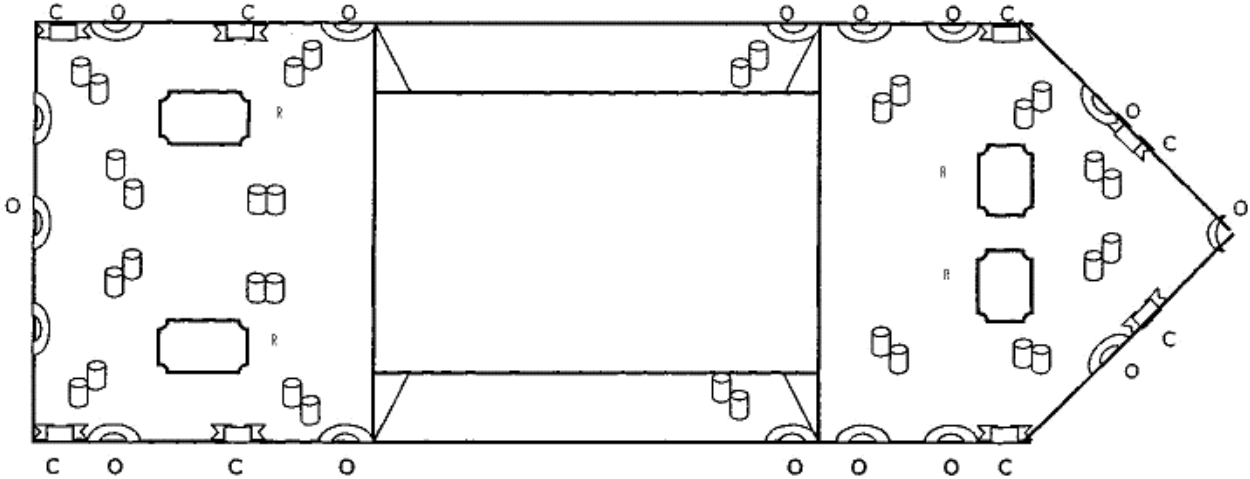

Mooring Winches

	No	Motive power (steam,hydraul)	Heaving power	Brake Capacity	Hauling speed
Forecastle	2	hydraulic	70 Kn	215 Kn	30 m/min
Poop	2	hydraulic	12 Kn	215 Kn	30 m/min

15.3	Anchors and Windlasses				
	Windlass motive Power	hydraulic			
	(steam, hydraulic)				
	Hauling power	Tonnes	120 Kn		
	Brake holding capacity	Tonnes	814 Kn		

Anchor type

Weight tonnes

Is spare carried

NO

Cable diameter Mm

No of shekels port 9

No of shekles starboard 10

15.4	Windage				
	Windage on ballast draught	M2			
	Windage full loaded	M2			

A16 NAVIGATIONAL EQUIPMENT

Is the following equipment fitted :		YES	NO
16.1	Magnetic compass	X	
16.2	Gyro compass and repeaters	X	
16.3	Radars	X	
16.4	Radar plotting equipment	X	
16.5	Arpa	X	
16.6	Echo sounder	X	
16.7	Speed/Distance indicator	X	
16.8	Doppler log	X	
16.9	Rudder angle, RPM, controllable pitch and Thrusters indicators	X	
16.10	Rate of turn indicator	X	
16.11	Radio D.F.	X	
16.12	Navtex receivers	X	
16.13	Satellite navigator	X	
16.14	Decca navigator		X
16.15	Loran C		X
16.16	Sextants	X	
16.17	Signal lamp (aldis)	X	
16.18	Course recorder	X	
16.19	Engine order printer		X
16.20	What chart outfit coverage is provided if limited, indicate areas covered	No limitation	
16.21	Formal chart correction system in use	Aut. Outf. Manag. System	

A17 COMMUNICATION EQUIPMENT

Is the following equipment fitted :

	YES	NO
17.1 Is ship with GMDSS	x	
17.2 Radio telegraph main transmitter including facility to transmit on radio telephone distress frequency	x	
17.3 Radio telegraph main receiver including facility to receive on radio telephone distress frequency	x	
17.4 Radio telephone distress frequency watch receiver	x	
17.5 Main radio antenna	x	
17.6 Radio telegraph reserve transmitter		X
17.7 Radio telegraph reserve receiver		X
17.8 Reserve radio antenna	x	
17.9 Are the main and reserve installation electrically separate and electrically independent of each other	x	
17.10 Radio telegraph auto alarm		x
17.11 2182 KHZ bridge watch receiver	X	
17.12 Alarm signal generating device	x	
17.13 VHF radio	X	
17.14 Inmarsat satellite communications system	X	
if yes, state identification number		
17.15 Telex	424798835	
if yes, state identification number		
17.16 Telex	424798836	
if yes, state identification number		
17.17 Weather fax	x	
17.18 Epirbs	x	
17.19 At least three survival craft two-way radio telephone apparatus	x	
17.20 Emergency lifeboat transmitter	x	
17.21 Full set of publications	x	
17.22 Satellite Epirb	x	
17.23 VHF Epirb		
17.24 Radio transponder for survival craft	x	

SECTION
B

B1 CARGO - GENERAL INFORMATION

- 1.1 List products which the ship is certified to carry
 Ammonia anhydrous, Butadiene, Butane, Butylenes, Ethane, Ethylene
 Isoprene, Butadiene and (C4) Hydrocarbon mixtures,
 Butane-Propane mixtures, Propane, Propylene
- 1.2 Minimum allowable tank temp. °C -104
- 1.3 Maximum permissible tank pressure Bar 5,7
- 1.4 List grades which can be transported simultaneously 2
- 1.5 List grades which can be loaded or discharged simultaneously 2
- 1.6 State natural tank segregation. (N.B. TK 1 in system I separation obtained by the removal of spools or by insertion of blind flange) TK 2 in system II
- 1.7 Number of products, (gas) that can be conditioned by reliquefaction simultaneously. 2

B2 CARGO TANKS

- 2.1 No. and type of cargo tanks 2 Type C 5% Nickel steel
- 2.2 Maximum allowable relief valve setting Bar 5,7
- 2.3 Safety valve set pressure - if give range for pilot valve variable 0,57 - 5,7
- 2.4 Maximum vacuum 0,75 kg/cm²
- 2.5 Maximum cargo density kg/cm²
- 2.6 Maximum rate of cool-down °C/hr
- 2.7 State any limitations regarding partially filled tanks no
- 2.8 State allowable combinations of filled and empty tanks No restriction

B3 CARGO TANK CAPACITIES

Complete the following table

TANK	Capacity CBM	Capacity CBM	PROPANE	AMMONIA	BUTANE	VCM
	100%	98%	Tonnes -42.8°C	Tonnes -33°C	Tonnes -0,5°C	Tonnes -13,4°C
1	4,387.261	4,299.516	2,500	2,924	2,655	4,393
2	4,619.499	4,527.109	2,632	3,080	2,630	4,172
3						
4						
5						
6						
TOTALS	9,006.760	8,826.625	5,464	6,004	5,285	8,565

B4 LOADING RATES

	PRODUCT	RATE (Tonnes/hr)	
		With vapour return	Without return
4.1	From refrigerated storage		
4.2	BUTANE	800 mt/h	
4.3	PROPANE	800 mt/h	
4.4	AMMONIA	400 mt/h	
4.5	ETHYLENE	600 mt/h	
4.6			
4.7			
4.8	From pressure storage		
4.9	BUTANE 0-30°C	435	435
4.10	PROPANE 0°C	500	500
4.11	10° C	500	500
4.12	20° C	500	150
4.13	30° C	400	100

B5 DISCHARGING - GENERAL

Cargo pumps

5.1	Type of pumps	DEEPWELL of Svanehoj DW 150/150-3-K-1
5.2	Number per tank	2
5.3	Rate (per pump)	250 cbm/h
5.4	Delivery head	120 mt
5.5	Maximum density	0,97 Kg/cbm
	Booster pumps	
5.6	Type of pump	BOOSTER of Svanehoj NMB150c
5.7	Number	1
5.8	Rate (per pump)	250 cbm/h
5.9	Delivery head	120 mt
5.10	Maximum density	Max 0,68 - 0,97 reduced

B6 DISCHARGE PERFORMANCES

Full cargo discharge times (using all main pumps)

	MANIFOLD BACK PRESSURE	Hours	
		With vapour return	Without return
6.1 From refrigerated			
6.2	1 bar (with 4 deepwell)	10	10
6.3	5 bar (with 4 deepwell)	10	10
6.4	10 bar (with 4 deepwell)	15	15

	MANIFOLD BACK PRESSURE	Hours	
		With vapour return	Without return
6.5 Pressurized			
6.6	1 bar (with 4 deepwell)		
6.7	5 bar (with 4 deepwell)	10	10
6.8	10 bar (with 4 deepwell)	15	15

B7 UNPUMPABLES

	TANKNO.	1	2	3	4	5	6	TOTAL TONNES
7.1	Vapour	9	9					18
7.2	Liquid	nil	nil					
7.3								Total quantity

B8 VAPORISING UNPUMPABLES

- 8.1 Process used
- Time to vaporise liquid unpumpables remaining after full cargo discharge :
- 8.2 - Propane **-Hrs 2**
 - 8.3 - Butane **- Hrs 8**
 - 8.4 - Ammonia **- Hrs 6**
 - 8.5 - Propylene **- Hrs 2**
 - 8.6 - **- hrs**
 - 8.7 - **- hrs**

B9 RELIQUEFACTION PLANT

- 9.1 Plant design conditions
- Air temperature 45 °C
Sea temperature 32 °C
- Plant type :
- 9.2 Single stage/direct **NO**
 - 9.3 Two stage/direct **YES**
 - 9.4 Simple cascade **YES**
 - 9.5 Coolant type **Sea water / Propylene**
 - Compressors **SULZER 2K 160 2 Q**
 - 9.6 Type **2**
 - 9.7 Number **1200 cbm/h with Butadiene - 900 cbm/h Ammonia / Ethylene**
 - 9.8 Capacity (per unit) **SULZER 2K 160 2 Q**
 - 9.9 Are they oil-free **x**

B10 COOLING CAPACITY

State cooling capacity (in Kcal/hr) for :

10.1	Propane	@ -42°C	Kcal/hr	170.000 (sea water 15°C)	120.000 (sea water 32°C)
10.2		@ -20°C	Kcal/hr		
10.3		@ - 5°C	Kcal/hr		
10.4	Butane	@ - 5°C	Kcal/hr	290.000 (sea water 15°C)	240.000 (sea water 32°C)
10.5		@ 0°C	Kcal/hr		
10.6		@ 0°C	Kcal/hr		

B11 CARGO TEMPERATURE LOWERING CAPABILITY (AT SEA)

Time taken to lower the temperature of:

11.1	Propane from	+10°C to -42°C	Hrs	165 (sea water 15°C)	Hrs	225 (sea water 32°C)
11.2		-5°C to -42°C	Hrs	145 (sea water 15°C)	Hrs	200 (sea water 32°C)
11.3		-38°C to -42°C	Hrs	30 (sea water 15°C)	Hrs	85 (sea water 32°C)
11.4		+20°C to -0.5°C	Hrs			
11.5		+10°C to -0.5°C	Hrs	10 (sea water 15°C)	Hrs	15 (sea water 32°C)
11.6	Butane from	+20°C to -0.5°C	Hrs	70 (sea water 15°C)	Hrs	80 (sea water 32°C)
11.7		+ 10°C to -0.5°C	Hrs	43 (sea water 15°C)	Hrs	53 (sea water 32°C)
11.8		+10°C to -5°C	Hrs			
11.9	Ethylene from	-95°C to -	Hrs	85 (sea water 15°C)	Hrs	95 (sea water 32°C)
11.10	Ethylene from	-98°C to -	Hrs	56 (sea water 15°C)	Hrs	60 (sea water 32°C)

B12 INERT GAS

Main inert gas and nitrogen plant

12.1	Type of system	12.1	Type of system
12.2	Capacity	12.2	Capacity
12.3	Composition of inert gas	12.3	Composition of inert gas
12.4	Dew point	12.4	Dew point
12.5	Used for Nitrogen	12.5	Used for Nitrogen
12.6	No of bottles	12.6	No of bottles
12.7	Capacity (each one)	12.7	Capacity (each one)
12.8	Used for	12.8	Used for

Main inert gas and nitrogen plant

Main inert gas and nitrogen plant

B13 CARGO TANK INERTING/DE-INERTING

13.1	Time taken from fresh air to under 5% O ₂ at -25°C dewpoint	12 hrs
	Time taken from cargo vapour to fully inert at -25°C dewpoint	15 hrs
13.2	When : Inert gas density less than product	hrs
	Inert gas density greater than product	hrs

B14 GAS FREEING TO FRESH AIR

14.1	Plant used	2 Cargo Compressors Plus dry Air plant
14.2	Time taken from fully inerted condition to fully breathable fresh air	15 hrs

B15 CHANGING CARGO GRADES

In this table write down time to change products (in hrs). Write also consumption of nitrogen.

From To	PROPANE TIME/CONS.	BUTANE TIME/CONS.	PROPYLENE TIME/CONS.	AMMONIA TIME/CONS.	VCM TIME/CONS.
PROPANE	XXXXXXXXXXXX	92 - 30000 cbm		92 – 30000cbm	92 – 30000 cbm
BUTANE	70 – 30000 cbm	XXXXXXXXXXXX		70 – 30000 cbm	70 – 30000 cbm
PROPYLENE			XXXXXXXXXXXX		
AMMONIA	85 – 30000 cbm	85 – 30000 cbm		XXXXXXXXXXXX	85 – 30000 cbm
VCM	75 – 30000 cbm	75 – 30000 cbm		75 – 30000 cbm	XXXXXXXXXXXX

B16 DECK TANK CAPACITY

16.1	Propane capacity	Cbm	NA
16.2	Butane capacity	Cbm	NA
16.3	Ammonia capacity	Cbm	NA
16.4	Nitrogen capacity	Ncm	NA

B17 PRE-LOADING COOLDOWN

In the table below, show time and quantity of coolant required to cooldown cargo tanks from ambient temperature and fully gassed up state sufficient to allow loading to commence.

	PRODUCT	QUANTITY REQUIRED	TIME	
			With return line	
17.1	ETHYLENE	100 cbm	8	17.1
17.2	PROPANE	50 cbm	6	17.2
17.3	BUTANE	30 cbm	3	17.3
17.4	AMMONIA	40 cbm	5	17.4
17.5	VINYL	35 cbm	3	17.5

B18 VAPORISER

18.1	Type of vaporiser	N.A.
18.2	Number fitted	
18.3	Capacity (per unit)	cbm/hr vapour
18.4	Liquid supply rate	cbm/hr liquid
18.5	Delivery temperature	°C

B19 BLOWER

19.1	Type of blower	WATER BLOWER
19.2	Rated capacity	5000 cbm/hr
19.3	Delivery pressure	0 kg/cm2

B20 CARGO RE-HEATER

20.1	Type of re-heater	Co-Current Shell & Horizontal Tubes
20.2	Number fitted	1
20.3	Heating medium	SEA WATER
20.4	Discharge rates with sea water at 15°C to raise product temperature:	
	for propane from -42°C to -5°C	110 cbm/hr
20.5	for ammonia from -33°C to 0°C	155 cbm/hr

B21 HYDRATE CONTROL

21.1	Freezing point temperature of Depressant	-97°C
21.2	Quantity of Depressant carried	litres
21.3	Means of injection	Hand pump

B22 CARGO MEASUREMENT

	LEVEL GAUGES		
21.1	Are level gauges local or remote	21.1	Are level
21.2	Manufacturer	21.2	Manufacturer
21.3	Type	21.3	Type
21.4	Rated accuracy	21.4	Rated accuracy
21.5	Certifying authority	21.5	Certifying authority
	TEMPERATURE GAUGES		
22.6	Manufacturer	22.6	Manufacturer
22.7	Type	22.7	Type
22.8	Rated accuracy	22.8	Rated accuracy
22.9	Certifying authority	22.9	Certifying authority
	PRESSURE GAUGES		
22.10	Manufacturer	22.10	Manufacturer
22.11	Type	22.11	Type
22.12	Rated accuracy	22.12	Rated accuracy
22.13	Certifying authority	22.13	Certifying authority
	OXYGEN ANALYSER		
22.14	Manufacturer	22.14	Manufacturer
22.15	Type	22.15	Type
	FIXED GAS DETECTOR		
22.16	Manufacturer	22.16	Manufacturer
22.17	Type	22.17	Type
22.18	No of points detected	22.18	No of points detected
	PORTABLE GAS DETECTOR		
22.19	Number	3	
22.20	Manufacturer	DRAGER	
22.21	Type	PAC EX-2	
	TOXIC GAS INDICATOR		
22.22	Number	22.22	Number
22.23	Type	22.23	Type
	TOXIC GAS INDICATOR TUBES		
22.24	Number	22.24	Number
22.25	Products	22.25	Products
22.26	Exp.dates	22.26	Exp.dates
	TANKSCOPE		
22.27	Type	22.27	Type

B23 CARGO SAMPLING

23.1 Fill the following table

CARGO TANKS	CARGO TANKS	CARGO TANKS	CARGO TANKS
1	1	1	1
2	2	2	2
3	3	3	3
4	4	4	4
5	5	5	5
6	6	6	6

23.2 Can sample be drawn from:

- | | | |
|------------------------|------------------------|------------------------|
| - Tank vapour outlet | - Tank vapour outlet | - Tank vapour outlet |
| - Manifold liquid line | - Manifold liquid line | - Manifold liquid line |
| - Manifold vapour line | - Manifold vapour line | - Manifold vapour line |
| - Pump discharge line | - Pump discharge line | - Pump discharge line |

23.3 State connection type and size

SCREW – 8 millimetres

23.3 State connection type and size

B24 CARGO MANIFOLD ARRANGEMENTS

CARGO MANIFOLD

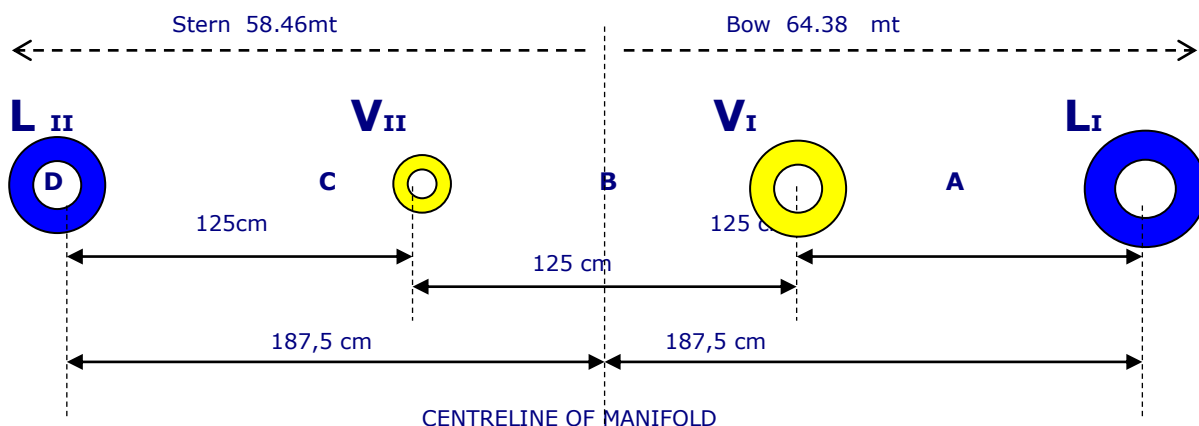

Pipe Flange	Duty	Rating	Size	Raised (R) or Flat (F) face
A	Liquid system I	Ansi 300	8"	R
B	Vapour " I	Ansi 150	6"	R
C	Vapour " II	Ansi 150	4"	R
D	Liquid system II	Ansi 300	6"	R

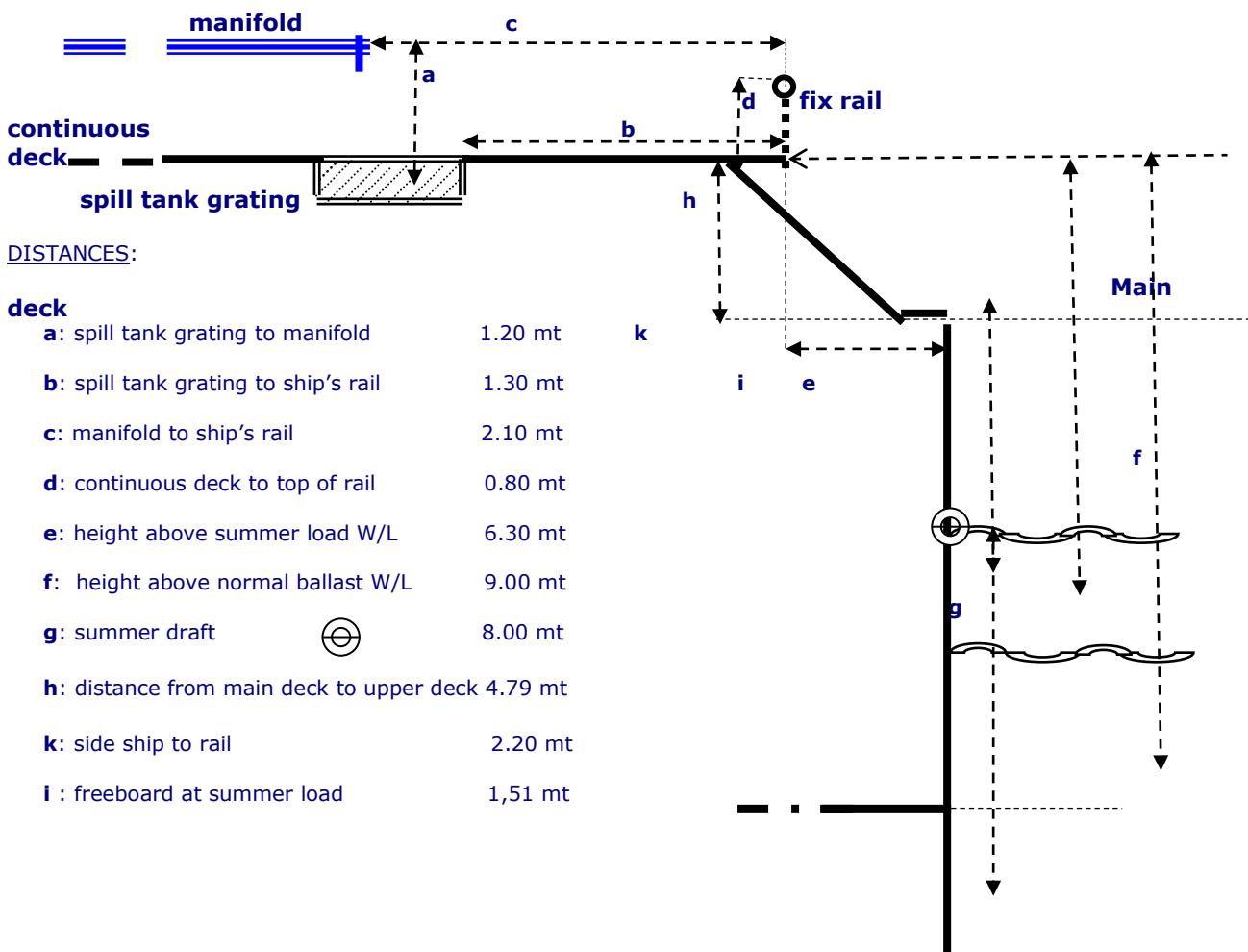

DISTANCES:

- deck**
- a:** spill tank grating to manifold 1.20 mt
 - b:** spill tank grating to ship's rail 1.30 mt
 - c:** manifold to ship's rail 2.10 mt
 - d:** continuous deck to top of rail 0.80 mt
 - e:** height above summer load W/L 6.30 mt
 - f:** height above normal ballast W/L 9.00 mt
 - g:** summer draft 8.00 mt
 - h:** distance from main deck to upper deck 4.79 mt
 - k:** side ship to rail 2.20 mt
 - i:** freeboard at summer load 1,51 mt

B 24bis CARGO MANIFOLD only port side main Deck

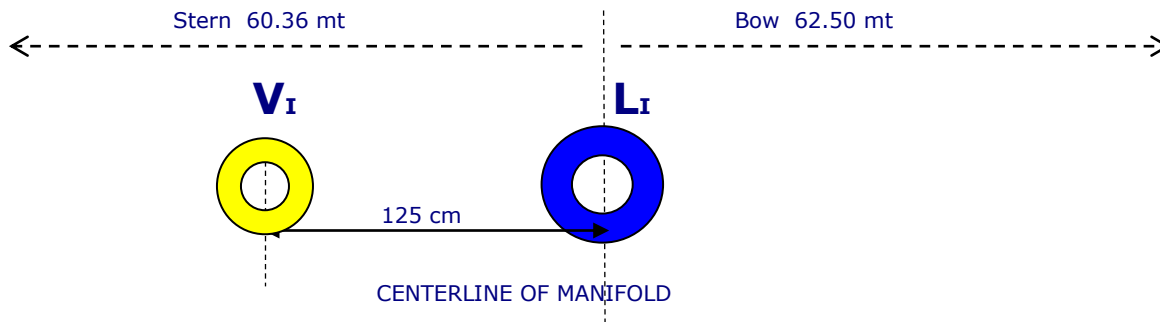

Pipe Flange	Duty	Rating	Size	Raised (R) or Flat (F) face
L ₁	Liquid system I	Ansi 300	8"	R
V ₁	Vapour " I	Ansi 150	6"	R

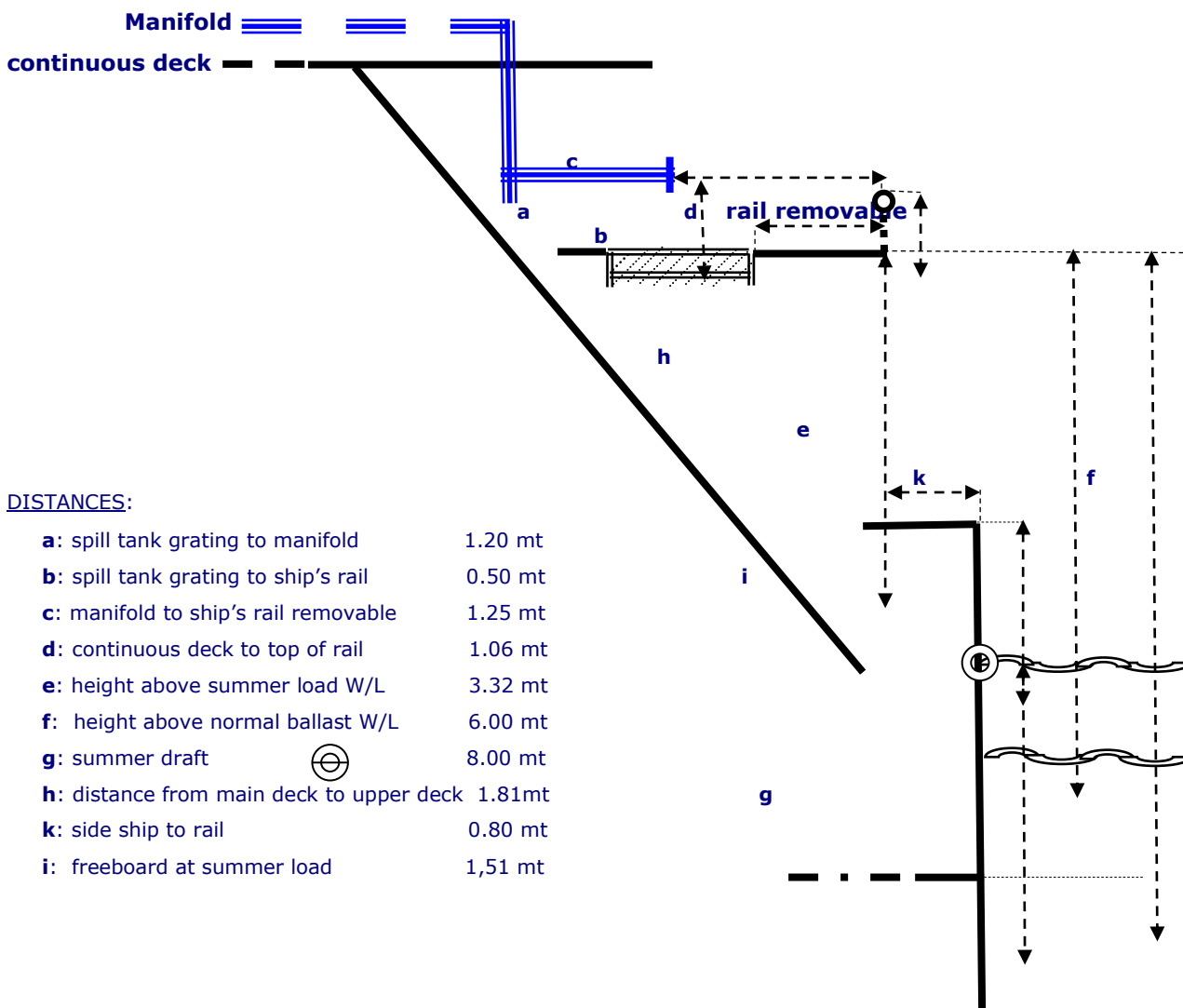

DISTANCES:

- a:** spill tank grating to manifold 1.20 mt
- b:** spill tank grating to ship's rail 0.50 mt
- c:** manifold to ship's rail removable 1.25 mt
- d:** continuous deck to top of rail 1.06 mt
- e:** height above summer load W/L 3.32 mt
- f:** height above normal ballast W/L 6.00 mt
- g:** summer draft 8.00 mt
- h:** distance from main deck to upper deck 1.81mt
- k:** side ship to rail 0.80 mt
- i:** freeboard at summer load 1,51 mt

CARGO SYSTEMS

B 24bls CARGO MANIFOLD only port side Main Deck

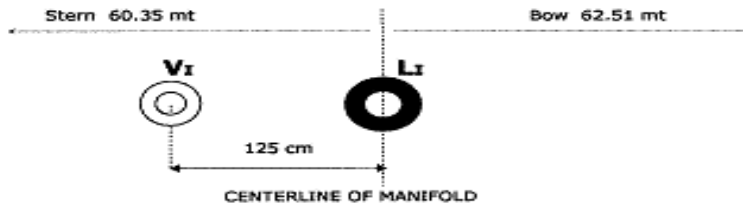

Pipe Flange	Duty	Rating	Size	Raised (R) or Flat (F) face
L ₁	Liquid system I	Ansi 300	8"	R
V ₁	Vapour " I	Ansi 150	6"	R

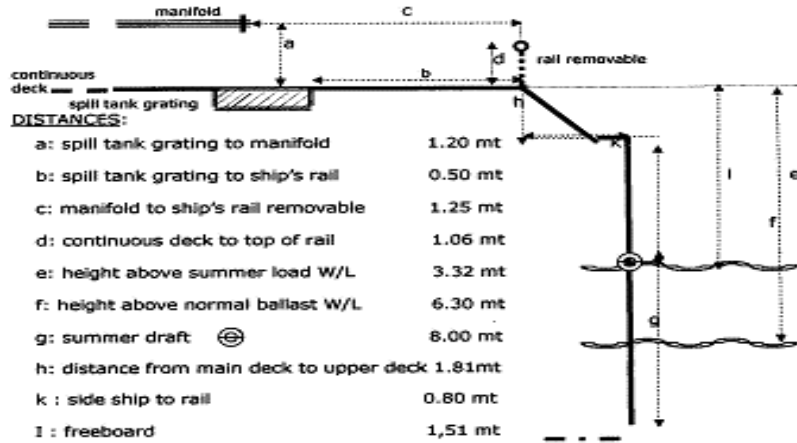

B25 CARGO MANIFOLD REDUCERS

State number of reducers carried on board and their flange rating and size

25.1	AISI class 300	<i>AMSI class 300 size 8" to size 10" AMSI class 300</i>
25.2		
25.3		
25.4	AISI class 300 to class 150	<i>AMSI class 300 size 8" to size 6" AMSI class 150</i>
25.5		
25.6		
25.7	AISI class 150	<i>AMSI class 150 size 6" to size 4" AMSI class 150</i>
25.8		<i>AMSI class 150 size 6" to size 6" AMSI class 150</i>
		<i>AMSI class 150 size 6" to size 8" AMSI class 150</i>
		<i>AMSI class 150 size 4" to size 4" AMSI class 300</i>

B26 MANIFOLD DERRICK/CRANE

26.1	Is Manifold Derrick provided	NO
26.2	Is Manifold Crane provided	YES
26.3	Is lifting equipment same port and starboard	YES
	If not give details	
26.4	State SWL at maximum outreach	4 Tonnes at maximum outreach 13mt (3,5mt from side)