



FORM C GAS

PGC PERIKLIS



MODEL

Form C gas

Index

SECTION A GENERAL INFORMATION

A1	Principal ship particulars	1
A2	Hull dimensions	1
A3	Ballast particulars	2
A4	Immersion	2
A5	Loaded particulars	2
A6	Parallel mid-body dimensions	3
A7	Bunker capacities	4
A8	Speed & Fuel consumption details	4
A9	Main engine particulars	4
A10	Auxiliary plant	4
A11	Power/Speed information	4
A12	Thrusters	5
A13	Fresh water	5
A14	Ballast capacities and pumps	5
A15	Mooring equipment	6
A16	Navigational equipment	7
A17	Communications equipment	8

SECTION B CARGO SYSTEMS

B1	Cargo - General information	9
B2	Cargo tanks	9
B3	Cargo tank capacities	10
B4	Loading rates	10
B5	Discharging - general	10
B6	Discharge performances	11
B7	Umpumpables	11
B8	Vaporising umpumpables	11
B9	Reliquefaction plant	11
B10	Cooling capacity	12
B11	Cargo temperature lowering capability (at sea)	12
B12	Inert gas	12
B13	Cargo tank inerting/de-inerting	12
B14	Cargo freeing to fresh air	12
B15	Changing cargo grades	13
B16	Deck tank capacities	13
B17	Pre-loading cooldown	13
B18	Vaporiser	13
B19	Blower	13
B20	Cargo Re-Heater	14
B21	Hydrate control	14
B22	Cargo measurement	14
B23	Cargo sampling	15
B24	Cargo manifold arrangements	16
B25	Cargo manifold reducers	17
B26	Manifold Derrick/Crane	17

GENERAL INFORMATION

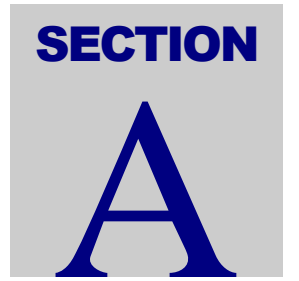

GENERAL INFORMATION

A1 PRINCIPAL SHIP PARTICULARS

1.1	Name of Ship	PGC PERIKLIS
1.2	Previous Name(s)	N/A
1.3	Builder	Kyokuyo, Japan
1.4	Date of delivery	7th July 2017
1.5	Classification Society	BV
1.6	Gross Registered Tonnage	6,248
1.7	Net registered Tonnage	2,095
1.8	Suez Tonnage Gross/Net	6,943.97/5,872.66
1.9	Panama tonn. Total Volume m3/Net	21,807/5,310
1.10	Registered Owner	PERIKLIS MARITIME LTD
	Address	Ajeltake Road, Ajeltake Island Majuro, Marshall Islands
	Telephone	
	Telex/fax	
1.11	Manager or Operator	Paradise Navigation SA
	Address	4-6 Solomou Str. N. Psychiko Greece
	Telephone	+30 210 6912010
	Telex/fax	+30 2106912272
1.12	Flag	Malta
1.13	Port of registry	Valletta
1.14	Official No.	9796171
1.15	Call Sign	9HA4614
1.16	Immarsat No.	424825310
1.17	LR/IMO No.	9796171
1.18	Was the ship built in accordance with the following regulations	
	IMO	YES
	USCG	YES
1.19	IMO Certification	
	Certificate of Fitness IGC	YES
	Letter of Compliance	YES
1.20	Date questionnaire compiled	07/07/2017

A2 HULL DIMENSIONS

2.1	Length overall	117.02 m
2.2	Length between perpendiculars	110.00 m
2.3	Extreme breadth	19.20 m
2.4	Extreme depth	9.0135 m
2.5	Summer draught	6.8135 m
2.6	Corresponding deadweight	6,849 Tonnes
2.7	Load displacement	
2.8	Load displacement (summer)	10,830.89 Tonnes
2.9	Cargo tank cubic capacity (100%)	7,542.962 m ³
2.10	Distance from keel to top antenna	36.15 m
2.11	Air draught (with normal ballast)	31.59 m

A3 BALLAST PARTICULARS

3.1	Permanent Ballast	N/A
3.2	Ballast quantity	911.0 Tonnes
3.3	Bunkers, stores, etc.	504.0 Tonnes
3.4	Draught	
	- Forward	2.335 m
	- Aft	5.539 m
	- Mean	3.937 m

A4 IMMERSION

4.1	TPC at normal draught	18.69 Tonnes at 5.80 m mean draught
4.2	TPC at loaded draught	19.66 Tonnes at 6.80 m mean draught

A5 LOADED PARTICULARS

5.1	Cargo	Butane	Propane	C4 (Butylene)	VCM
5.2	Density	0.607	0.539	0.627	0.966
5.3	Cargo tons	4,487.1	3,984.4 (98%)	4,634.9 (98%)	5,357.4 (73.5%)
5.4	Bunkers IFO	433.6	433.6	433.6	433.6
5.5	GASOIL	-	-	-	-
5.6	Fresh water	205.3	205.3	205.3	205.3
5.7	Stores/spares	-	-	-	-
5.8	Lub oil	-	-	-	-
5.9	Ballast	148.8	151.5	148.8	706.2
5.10	Deadweight	5,421.1	4,921.1	5,569.0	6,848.9
5.11	Draught				
	- Forward	5.140	4.682	5.276	6.249
	- Aft	6.828	6.731	6.857	7.258
	- Mean	5.984	5.707	6.066	6.754

Cargo temperature -10°C

5.1	Cargo	Mix: 50/50	Mix: 30/70 -	Mix:70/30	-
5.2	Density	0.572	0.582	0.562	
5.3	Cargo tons	4,228.3 (98%)	4,302.2 (98%)	4,154.4 (98%)	
5.4	Bunkers IFO	433.6	433.6	433.6	
5.5	GASOIL	-	-	-	
5.6	Fresh water	205.3	205.3	205.3	
5.7	Stores/spares	-	-	-	
5.8	Lub oil	-	-	-	
5.9	Ballast	148.8	309.0	255.1	
5.10	Deadweight	5,162.4	5,396.5	5,194.8	
5.11	Draught				
	- Forward	4.903	5.235	4.903	
	- Aft	6.778	6.730	6.808	
	- Mean	5.841	5.983	5.855	

A6 PARALLEL MID-BODY DIMENSIONS

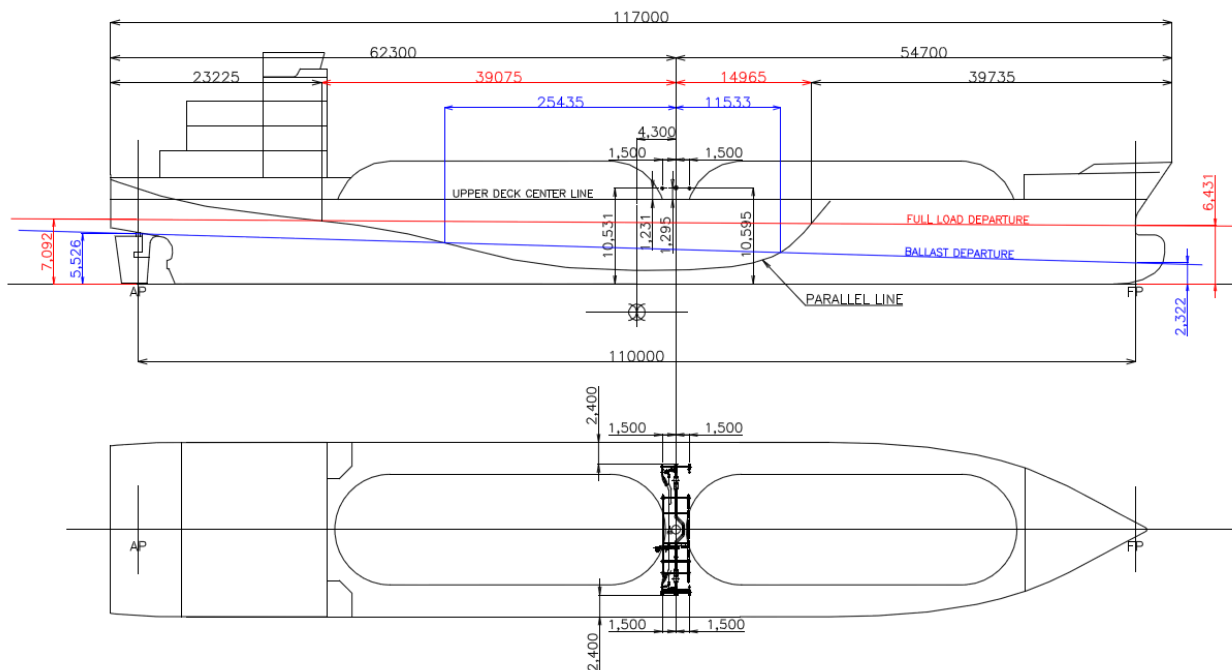

A7 BUNKER CAPACITIES

7.1	M.E. Fuel Oil	Grade	IFO 380	($\bar{\delta}$: 0,980)
		Capacity 98%	499.91 Tonnes	
7.2	Diesel Oil	Grade	($\bar{\delta}$: 0,840)	
		Capacity 98%	80.23 Tonnes	

A8 SPEED & FUEL CONSUMPTION DETAILS

8.1	At sea, laden speed 12.50 kts / ballast speed 13.30	FO	7.6 ton/day
	At sea, laden speed 13.20 kts / ballast speed 14.20	FO	9.1 ton/day
	At sea, laden speed 13.90 kts / ballast speed 15.10	FO	11.0 ton/day
	At sea	GO	1.1 ton/day
8.2	At sea (normal service speed) while conditioning cargo	N/A	
8.3	In port, loading	FO	ton/day
		GO	1.7 ton/day
8.4	In port, discharging	FO	ton/day
		GO	3.5 ton/day
8.5	In port, idle	FO	ton/day

GENERAL INFORMATION

	GO	ton/day
--	----	---------

A9 MAIN ENGINE PARTICULARS

9.1	Main engine make and type	Makita Corporation / MAN B&W 6L35MC6.1 (De-rated)
9.2	No. of units	1
9.3	Maximum continuous rating (MCR) per engine	178.0 rpm
9.4	Total available power	2,640 kW
9.5	Normal service power (ECR)	2,376 kW at 171.9 rpm

A10 AUXILIARY PLANT

10.1	Make and type of auxiliary generators	Taiyo Electric Co., Ltd. FE 540L-6
10.2	No. of units	2
10.3	Maximum generator output per unit	480 kW
10.4	Shaft generator	N/A
10.5	Emergency generator	96 kW
10.6	Total available power	960 kW

A11 POWER/SPEED INFORMATION

11.1	Trial data	BHP	2,656 kW
		MCR	
		Speed	15.63 kts
		Draught	3.820 m
11.2	Normal service speed	BHP	2,376 kW
		MCR	
		Speed	Abt 13.6 kts
		Draught	5.814 m

A12 THRUSTERS

12.1	Make and type	KAWASAKI KT-43B1
12.2	No. Installed	1
12.3	Location and rated bollard pull	FORE (Fr. 149) – 5 Ton Nominal Thrust

A13 FRESH WATER

13.1	Capacity of distilled tanks	100.40 m ³
13.2	Capacity of domestic tanks	104.85 m ³
13.3	Daily consumption distilled	

GENERAL INFORMATION

domestic	
13.4 Daily evaporator production	Abt. 9 tonnes/day

A14 BALLAST CAPACITIES AND PUMPS

Fill the following table		
	Tank	Capacity (m ³)
14.1	Fore peak	118.73
14.2	Wing or side tanks	1,726.28
14.3	Double bottoms	-
14.4	Aft peak	226.74
14.5	Other	-
14.6	Total	2,071.75
14.7	Ballast pump make and type	Centrifugal - TAIKO KIKAI EMCN 200MD
14.8	No. of Pumps	2
14.9	Total capacity	500 m ³ /h (2 x 250m ³ /h)
14.10	Location	Engine Room Lower Floor (FR.29 – 30)
14.11	Control Location	Engine Control Room and Cargo Monitoring Room

A15 MOORING EQUIPMENT

15.1 Ropes and Wires.

On the diagram below indicate the position of winch mounted wires (W) and ropes (R) together with open (O) and closed (C) fairleads.

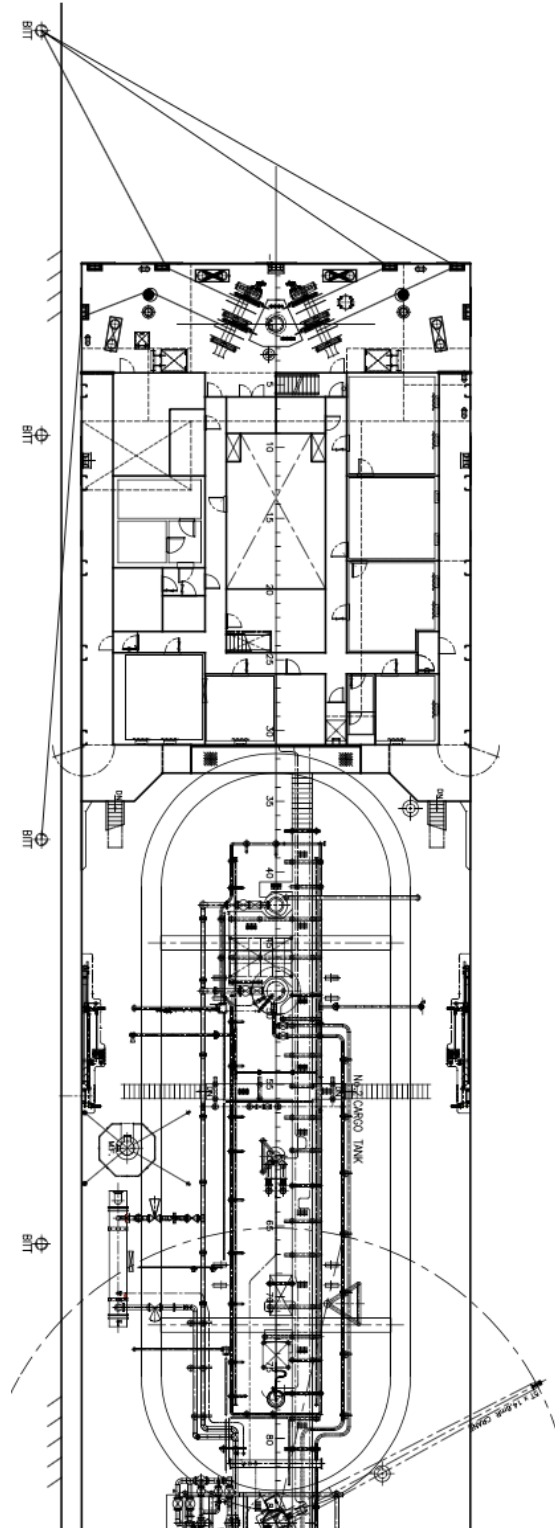

GENERAL INFORMATION

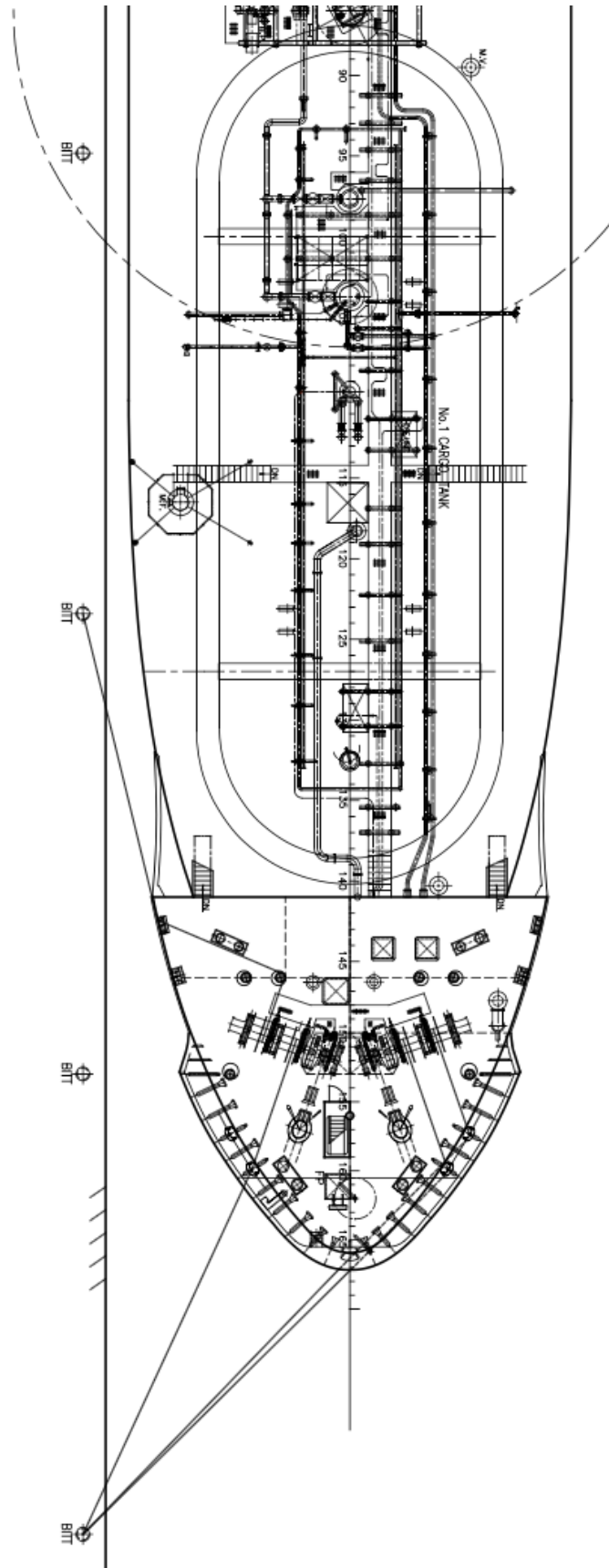

GENERAL INFORMATION

Mooring Winches					
	No	Motive power (steam,hydraulic)	Heaving power	Brake Capacity	Hauling speed
Forecastle	2	hydraulic	74.5 kN	245 kN	15 m/min
Poop	2	hydraulic	74.5 kN	245 kN	15 m/min
15.3	Anchors and Windlasses				
	Windlass motive Power (steam, hydraulic)	hydraulic			
	Hauling power	Tonnes	124.5 kN		
	Brake holding capacity	Tonnes	716 kN		
	Date of last test				
	Anchor type	Stockless AC14 Type			
	Weight	Each anchor 2.840 tonnes			
	Is spare carried	NO			
	Cable diameter	54 mm			
	No of shackles port	9			
	No of shackles starboard	10			
15.4	Windage				
	Windage on ballast draught	m ²			
	Windage full loaded	m ²			

A16 NAVIGATIONAL EQUIPMENT

Is the following equipment fitted :	YES	NO
16.1 Magnetic compass	x	
16.2 Gyro compass and repeaters	x	
16.3 Radars	x	
16.4 Radar plotting equipment	x	
16.5 Arpa	x	
16.6 Echo sounder	x	
16.7 Speed/Distance indicator	x	
16.8 Doppler log	x	
16.9 Rudder angle, RPM, controllable pitch and Thrusters indicators	x	
16.10 Rate of turn indicator	x	
16.11 Radio D.F.		x
16.12 Navtex receivers	x	
16.13 Satellite navigator	x	
16.14 Decca navigator		x
16.15 Loran C		x
16.16 Sextants	x	
16.17 Signal lamp (aldis)	x	
16.18 Course recorder	x	
16.19 Engine order printer		x
16.20 What chart outfit coverage is provided if limited, indicate areas covered	No limitation	
16.21 Formal chart correction system in use	Chartco	

A17 COMMUNICATION EQUIPMENT

Is the following equipment fitted :		YES	NO
17.1	Is ship with GMDSS	X	
17.2	Radio telegraph main transmitter including facility to transmit on radio telephone distress frequency		X
17.3	Radio telegraph main receiver including facility to receive on radio telephone distress frequency		X
17.4	Radio telephone distress frequency watch receiver	X	
17.5	Main radio antenna	X	
17.6	Radio telegraph reserve transmitter		X
17.7	Radio telegraph reserve receiver		X
17.8	Reserve radio antenna		X
17.9	Are the main and reserve installation electrically separate and electrically independent of each other		X
17.10	Radio telegraph auto alarm		X
17.11	2182 KHZ bridge watch receiver	X	
17.12	Alarm signal generating device	X	
17.13	VHF radio	X	
17.14	Inmarsat satellite communications system	X	
	if yes, state identification number		
17.15	Telephone		
	if yes, state identification number		
17.16	Telephone		
	if yes, state identification number		
17.17	Weather fax	X	
17.18	Epirbs		X
17.19	At least three survival craft two-way radio telephone apparatus	X	
17.20	Emergency lifeboat transmitter		X
17.21	Full set of publications	X	
17.22	Satellite Epirb	X	
17.23	VHF Epirb		X
17.24	Radio transponder for survival craft	X	

CARGO SYSTEMS

B 1 CARGO - GENERAL INFORMATION

1.1	List products which the ship is certified to carry	Propylene, Propane, Butane, Butane-propane mixtures, Butylenes (inhibited), Butadiene (inhibited), Isoprene (inhibited), Vinyl Chloride Monomer (V.C.M.), Pentanes, Pentene
1.2	Minimum allowable tank temp.	-10 °C
1.3	Maximum permissible tank pressure	17.7 Bar (1.77 Mpa)
1.4	List grades which can be transported simultaneously	2
1.5	List grades which can be loaded or discharged simultaneously	1
1.6	State natural tank segregation. (N.B. separation obtained by the removal of spools or by insertion of blind flange)	By blind flange
1.7	Number of products, (gas) that can be conditioned by reliquefaction simultaneously.	N/A

B2 CARGO TANKS

2.1	No. and type of cargo tanks	2 Tanks - Type C
2.2	Maximum allowable relief valve setting	17.3 Bar Gauge
2.3	Safety valve set pressure - if variable give range for pilot valve	N/A
2.4	Maximum vacuum	0.344 Mpa
2.5	Maximum cargo density	0.966 Ton/m ³ (VCM)
2.6	Maximum rate of cool-down	°C/hr
2.7	State any limitations regarding partially filled tanks	No limitations
2.8	State allowable combinations of filled and empty tanks	No Restriction

B3 CARGO TANK CAPACITIES (including tank dome)

Complete the following table

TANK	Capacity CBM	Capacity CBM	PROPANE	AMMONIA	BUTANE	VCM
	100%	98%	Tonnes -42.8°C	Tonnes -33°C	Tonnes -0.5°C	Tonnes -10°C
1	3772.6	3697.1	1687.2	2032.5	3205.1	3772.6
2	3772.7	3697.3	1687.3	2032.6	3205.3	3772.7
TOTALS	7545.3	7394.4	3374.5	4065.1	6410.4	7545.3

B4 LOADING RATES

	PRODUCT	RATE (Tonnes/hr)	
		With vapour return	Without return
4.1	From refrigerated storage		
4.2	BUTANE		
4.3	PROPANE		
4.4			
4.5			
4.6			
4.7			
4.8	From pressure storage		
4.9	BUTANE 0-30°C	480	
4.10	PROPANE 0°C	420	
4.11	10° C		
4.12	20° C		
4.13	30° C		

B5 DISCHARGING - GENERAL

Cargo pumps		
5.1	Type of pumps	Elect. Motor Driven Vertical Turbine (deep well pump)
5.2	Number per tank	1
5.3	Rate (per pump)	LPG 400 m ³ /h, VCM 200 m ³ /h
5.4	Delivery head	LPG 110 m , VCM 148 m
5.5	Maximum density	0.949
Booster pumps		
5.6	Type of pump	Elect. motor driven NMB 150C
5.7	Number	1
5.8	Rate (per pump)	300 m ³ /h
5.9	Delivery head	110 m
5.10	Maximum density	0.657

B6 DISCHARGE PERFORMANCES

Full cargo discharge times (using all main pumps)

		MANIFOLD		Hours	
		BACK PRESSURE		With vapour return	Without return
6.1	From refrigerated				
6.2		1 bar (with 2 deepwell)			
6.3		2 bar (with 2 deepwell)			
6.4		3 bar (with 2 deepwell)			
<hr/>					
		MANIFOLD		Hours	
		BACK PRESSURE		With vapour return	Without return
6.5	Pressurized				
6.6		1 bar (with 2 deepwell)			
6.7		2 bar (with 2 deepwell)			
6.8		3 bar (with 2 deepwell)			

B7 UNPUMPABLES

	TANKNO.	1	2	3	4	5	6	TOTAL TONNES
7.1	Vapour							
7.2	Liquid	0.5 m3	0.5 m3					1.0 m3
7.3							Total quantity	

B8 VAPORISING UNPUMPABLES

- 8.1 Process used
Time to vaporise liquid unpumpables remaining after full cargo discharge :
- 8.2 - Propane
- 8.3 - Butane
- 8.4 - Ammonia
- 8.5 - Propylene
- 8.6 -
- 8.7 -

B9 RELIQUEFACTION PLANT

N/A

- 9.1 Plant design conditions
Air temperature °C
Sea temperature °C
- Plant type :
- 9.2 Single stage/direct
- 9.3 Two stage/direct
- 9.4 Simple cascade
- 9.5 Coolant type
- Compressors
- 9.6 Type
- 9.7 Number
- 9.8 Capacity (per unit)
- 9.9 Are they oil-free

B10 COOLING CAPACITY

State cooling capacity (in Kcal/hr) for :

- 10.1 Propane @ °C
- 10.2 @ °C
- 10.3 @ °C
- 10.4 Butane @ °C
- 10.5 @ °C
- 10.6 @ °C

B11 CARGO TEMPERATURE LOWERING CAPABILITY (AT SEA)

Time taken to lower the temperature of:

- 11.1 Propane from °C to °C
- 11.2 °C to °C
- 11.3 °C to °C
- 11.4 °C to °C
- 11.5 °C to °C
- 11.6 Butane from °C to °C
- 11.7 °C to °C
- 11.8 °C to °C

B12 INERT GAS

Main inert gas and nitrogen plant																			
12.1 Type of system	PSA type Nitrogen Gas Generating Equipment																		
12.2 Capacity	99.9%N ₂ 400 Nm ³ /hr, 97.0%N ₂ 780Nm ³ /hr																		
12.3 Composition of inert gas	<table style="width: 100%; border: none;"> <tr> <td style="width: 30%;"></td> <td style="width: 35%;">N₂ 99.9%</td> <td style="width: 35%;">N₂ 97.0%</td> </tr> <tr> <td>O₂ :</td> <td>< 0.1%</td> <td>< 3.0%</td> </tr> <tr> <td>CO₂ :</td> <td>< 5ppm</td> <td>< 20ppm</td> </tr> <tr> <td>NO_x :</td> <td>Nil</td> <td>Nil</td> </tr> <tr> <td>N₂ :</td> <td>99.9%*</td> <td>97.0%*</td> </tr> <tr> <td></td> <td colspan="2">*incl. Argon abt.1.5%</td> </tr> </table>		N ₂ 99.9%	N ₂ 97.0%	O ₂ :	< 0.1%	< 3.0%	CO ₂ :	< 5ppm	< 20ppm	NO _x :	Nil	Nil	N ₂ :	99.9%*	97.0%*		*incl. Argon abt.1.5%	
	N ₂ 99.9%	N ₂ 97.0%																	
O ₂ :	< 0.1%	< 3.0%																	
CO ₂ :	< 5ppm	< 20ppm																	
NO _x :	Nil	Nil																	
N ₂ :	99.9%*	97.0%*																	
	*incl. Argon abt.1.5%																		
12.4 Dew point	Nor. Minus(-) 60 degC Max. Minus(-) 72 degC																		
12.5 Used for	Inerting, Purging and Gas-Freeing																		
Nitrogen																			
12.6 No of bottles	N/A																		
12.7 Capacity (each one)	N/A																		
12.8 Used for																			
Main inert gas and nitrogen plant	Nitrogen																		

B13 CARGO TANK INERTING/DE-INERTING

- 13.1 Time taken from fresh air to under 5% O₂ at -25°C dewpoint
Time taken from cargo vapour to fully inert at -25°C dewpoint

11.5 hrs
Abt. 69.85 hrs (N₂ 99.5 vol%, Cargo vapor 0.4 vol% and O₂ approx. 0.1 vol%)

- 13.2 When : Inert gas density less than product

Inert gas density greater than product

N₂ density is lighter than any Product

B14 GAS FREEING TO FRESH AIR

14.1	Plant used	N2 Generating System
14.2	Time taken from fully inerted condition to fully breathable fresh air	10.2 hrs

B15 CHANGING CARGO GRADES

In this table write down time to change products (in hrs). Write also consumption of nitrogen.

	From To	PROPANE TIME/CONS.	BUTANE TIME/CONS.	PROPYLENE TIME/CONS.	AMMONIA TIME/CONS.	VCM TIME/CONS.
	PROPANE					
	BUTANE					
	PROPYLENE					
	AMMONIA					
	VCM					

B16 DECK TANK CAPACITY

16.1	Propane capacity	Cbm	NA
16.2	Butane capacity	Cbm	NA
16.3	Ammonia capacity	Cbm	NA
16.4	Nitrogen capacity	Ncm	NA

B17 PRE-LOADING COOLDOWN

In the table below, show time and quantity of coolant required to cooldown cargo tanks from ambient temperature and fully gassed up state sufficient to allow loading to commence.

	PRODUCT	QUANTITY REQUIRED	TIME	
			With return line	
17.1				
17.2	PROPANE			
17.3	BUTANE			
17.4	AMMONIA			
17.5	VINYL			

B18 VAPORISER

18.1	Type of vaporiser	N.A.
18.2	Number fitted	
18.3	Capacity (per unit)	cbm/hr vapour
18.4	Liquid supply rate	cbm/hr liquid
18.5	Delivery temperature	°C

B19 BLOWER

19.1	Type of blower	
19.2	Rated capacity	
19.3	Delivery pressure	

B20 CARGO RE-HEATER

20.1	Type of re-heater	Horizontal Shell and Tube
20.2	Number fitted	1
20.3	Heating medium	Sea Water
Discharge rates with sea water at 18°C to raise product temperature:		
20.4	for propane from -48°C to -10°C	550m ³ /h
20.5	for ammonia from -°C to °C	

B21 HYDRATE CONTROL

21.1	Freezing point temperature of Depressant	
21.2	Quantity of Depressant carried	
21.3	Means of injection	

B22 CARGO MEASUREMENT

LEVEL GAUGES		
21.1	Are level gauges local or remote	Remote
21.2	Manufacturer	MUSASINO CO., LTD.
21.3	Type	Magnetic Float Type
21.4	Rated accuracy	±10mm
21.5	Certifying authority	BV
TEMPERATURE GAUGES		
22.6	Manufacturer	HYODA INSTRUMENTS CORP.
22.7	Type	Drip-proof type
22.8	Rated accuracy	±2°C
22.9	Certifying authority	
PRESSURE GAUGES		
22.10	Manufacturer	NAGANO KEIKI CO.,LTD
22.11	Type	Weather proof type
22.12	Rated accuracy	±1.6% F.S.
22.13	Certifying authority	
OXYGEN ANALYSER		
22.14	Manufacturer	
22.15	Type	
FIXED GAS DETECTOR		
22.16	Manufacturer	
22.17	Type	
22.18	No of points detected	
PORTABLE GAS DETECTOR		
22.19	Number	
22.20	Manufacturer	
22.21	Type	
TOXIC GAS INDICATOR		
22.22	Number	
22.23	Type	
TOXIC GAS INDICATOR TUBES		
22.24	Number	
22.25	Products	
22.26	Exp.dates	
TANKSCOPE		
22.27	Type	

B23 CARGO SAMPLING

23.1 Fill the following table			
CARGO TANKS	CARGO TANKS	CARGO TANKS	CARGO TANKS
1	1	1	1
2	2	2	2
23.2 Can sample be drawn from:			
- Tank vapour outlet	- Tank vapour outlet	- Tank vapour outlet	
- Manifold liquid line	- Manifold liquid line	- Manifold liquid line	
- Manifold vapour line	- Manifold vapour line	- Manifold vapour line	
- Pump discharge line	- Pump discharge line	- Pump discharge line	
23.3 State connection type and size	SCREW – 10.5 millimetres	23.3 State connection type and size	

B24 CARGO MANIFOLD ARRANGEMENTS

CARGO MANIFOLD

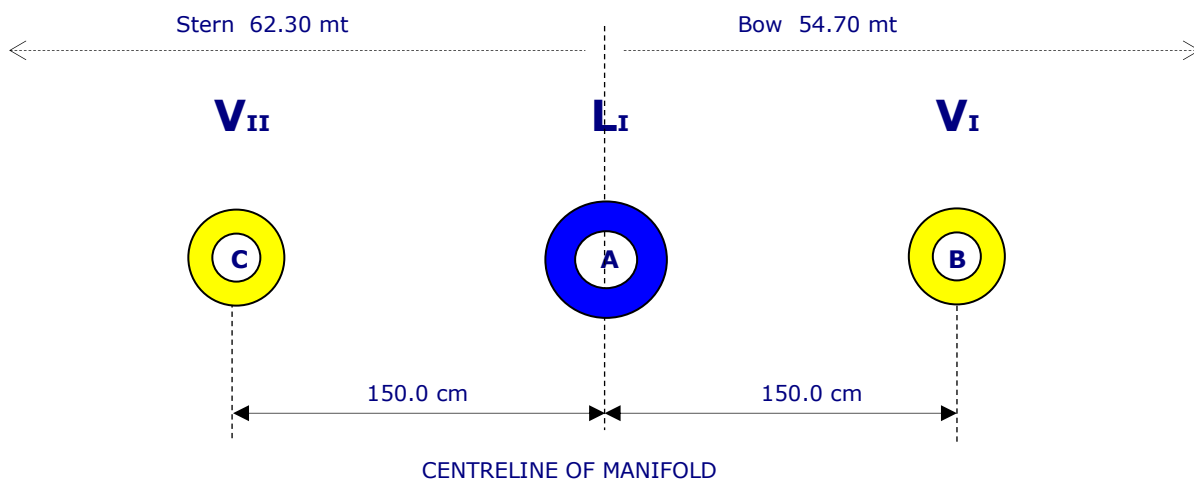

Pipe Flange	Duty	Rating	Size	Raised (R) or Flat (F) face
A	Liquid system I	Ansi 300	10"	R
B	Vapour " I	Ansi 300	6"	R
C	Vapour " II	Ansi 300	6"	R

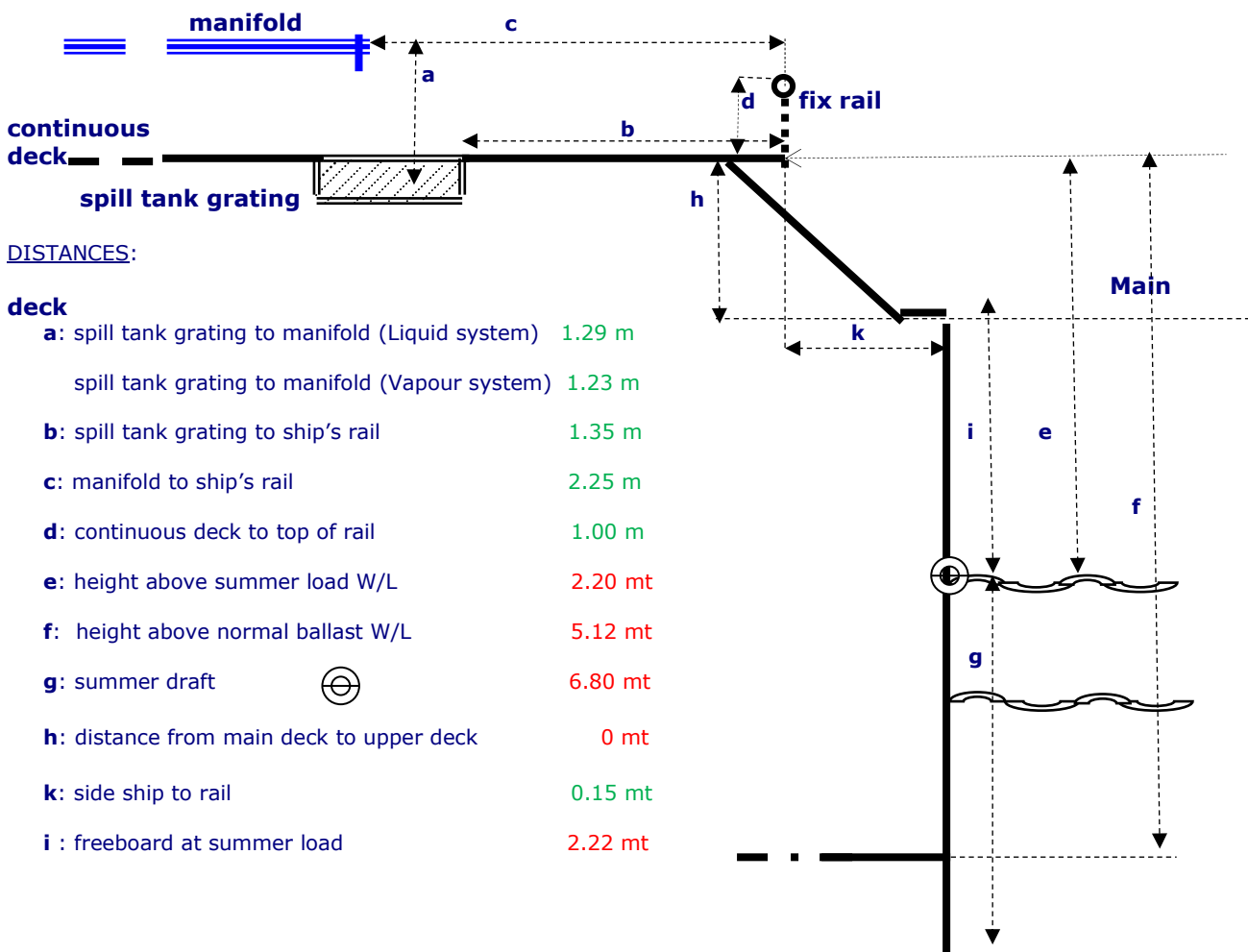

B25 CARGO MANIFOLD REDUCERS

- For Liquid (design temperature: -48°C)

Ship Side	Terminal Side	Quantity
ANSI #300-250A	ANSI #300-300A	1
ANSI #300-250A	ANSI #300-200A	1
ANSI #300-250A	ANSI #300-150A	1
ANSI #300-250A	ANSI #300-125A	1
ANSI #300-250A	ANSI #300-100A	1
ANSI #300-250A	ANSI #300-80A	1
ANSI #300-250A	ANSI #150-250A	1
ANSI #300-250A	ANSI #150-200A	1
ANSI #300-250A	ANSI #150-150A	1
ANSI #300-250A	ANSI #150-125A	1

- For Vapor (design temperature: -10°C)

Ship Side	Terminal Side	Quantity
ANSI #300-150A	ANSI #300-200A	1
ANSI #300-150A	ANSI #300-125A	1
ANSI #300-150A	ANSI #300-100A	1
ANSI #300-150A	ANSI #300-80A	1
ANSI #300-150A	ANSI #300-50A	1
ANSI #300-150A	ANSI #150-200A	1
ANSI #300-150A	ANSI #150-150A	1
ANSI #300-150A	ANSI #150-125A	1
ANSI #300-150A	ANSI #150-100A	1

GENERAL INFORMATION

ANSI #300-150A	ANSI #150-80A	1
----------------	---------------	---

B26 MANIFOLD DERRICK/CRANE

26.1	Is Manifold Derrick provided	NO	
26.2	Is Manifold Crane provided	YES	
26.3	Is lifting equipment same port and starboard	YES	
	If not give details	(Welded steel post arranged at the Centre Line of the vessel)	
26.4	State SWL at maximum outreach	5 Tonnes at maximum outreach of 14.6 m (5 m from side)	